



ÖZAK

TURNSTILES

[ozak - t . com](http://ozak-t.com)



ozak-t.com

ACCESS TECHNOLOGIES

About us...

OZAK was founded in 1974 and is proud of being the first and leading pedestrian and vehicle access control solutions producer in Turkey. OZAK; providing high quality and reliable solutions, is the correct choice for many companies in a broad geography covering more than 80 countries. Like no other company in the field; the capability of developing customised solutions in close cooperation with its customers is the reason behind this success.

OZAK has an ISO 9001:2008 registered manufacturing facility with a total area of 14.000 m² of which 9600 m² covered, available to work with you to develop and bring your project to life in the most cost-effective way possible.

The product range includes “pedestrian” and “vehicle” passage control systems in following type of products:

- **Waist & Full Height turnstiles,**
- **Speed Gates,**
- **Paddle Gate,**
- **Sliding Gate,**
- **Optical Turnstile,**
- **Disabled Passage Turnstiles,**
- **Stadium Solutions Integrated Turnstiles,**
- **Fuel Oil / Gas and Petroleum Refinery Turnstiles,**
- **Prestigious Passage Turnstiles and Doors for Business Center And Plazas,**
- **Motorised Swing Gates,**
- **Motorised Flap Doors,**
- **Emergency Exit Doors / Pedestrian Gates,**
- **Custom Designed Turnstiles and Passage Control Systems,**
- **“Road Blocker” Barrier Systems**
- **“Bollard” Barrier Systems**
- **Tyre Killer / Spike Barrier Systems**
- **Arm Barriers**



OZAK has a comprehensive reference range with its applications in Europe, Middle East, Arabian Peninsula, Far East, Asia, Africa and Russia such as:



- **Stadium Complexes,**
- **Fitness and Sport Halls,**
- **Airport Premises,**
- **Metro and Mass Transportation Systems,**
- **Environmental Control Systems in Outdoor/Indoor Public Areas,**
- **State Institutions,**
- **Industrial Plants,**
- **Construction Sites,**
- **Universities and other Education Institutions,**
- **Military and Defence Facilities,**
- **Power Plants,**
- **Business Centers and Plazas,**
- **Food Industry Applications,**
- **Health Facilities,**
- **Tourism and Historical Facilities,**
- **Ticket Authentication and Process Integration Applications.**

OZAK, investing in human resources, technology and environmental protection; thanks to its talented designers and engineers, design and build products using the state of the art technologies and flexible manufacturing processes. R&D activities are handled by a team of professionals and each team member offers his utmost contribution to provide the customers with the solutions which meets overall demands of the security sector based on the vision of cost effective innovations.





Waist Height Turnstiles - **Tripods**



602



- Power Requirements** : 110/220-240 V. 60/50 Hz. AC (%±10) 24 V. DC at standby ~4,5 W. max. ~13 W.
- Arms** : Ø40 mm x 2 mm 304 grade stainless steel (Opt. 316 - grade stainless steel).
- Body Features** : 304-grade (Opt. 316-grade) stainless steel with brushed (Opt. satin) surface.
- Operation Temperature, Humidity, IP Rating, MCBF** : -20°C to +68°C (-50°C with optional heater unit), RH 95% non-condensing / IP 54 outdoor model (Opt. IP 56) / 1M cycles
- Control System** : All inputs are opto-coupler protected. Compatible with all access control systems that provide dry contact or grounding outputs. Optional RS232/RS485/TCP IP control modules is available.
- Operation** : Manually operated bi-directional system (optional motorized) with dip switch selectable operational modes including controlled access on both sides, one side free (exit or entry), other side controlled access and access restriction modes.
- Emergency Mode** : System allows free passage in emergency mode and in case of power failure.
- Flow Rate** : Capacity of mechanism (manual system): max. 97 passages/minute, nominal: ~20 passages/minute
Capacity of mechanism (motorized system): max. 48 passages/minute, nominal: ~16 passages/minute
- Standard Features** : Direction and status indicators on top and sides.
- Optional Accessories and Applications** : Remote control units, interface unit for PC, RS485, RS232 and LAN, counter, audio-messaging system, motor driven unit, automatic drop (retractable) arm, alarm sensor, heater positive unit, coin slot/intelligent coin system and coin box, card reader pole, pipe barrier (separator), floor mounting plate, customised top covers to accommodate various accessories.

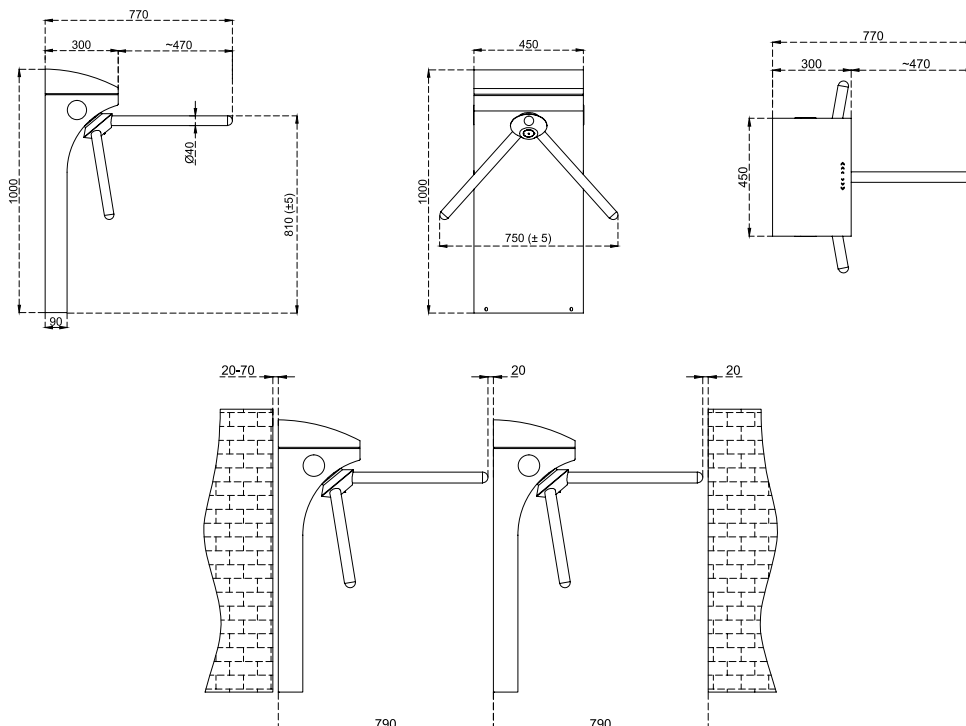

**Design and specifications are subject to change without notice. *All dimensions are in mm.*

602 D



- Power Requirements** : 110/220-240 V. 60/50 Hz. AC (%±10) 24 V. DC at standby ~4,5 W + 4,5 W. max. ~13 W + 13W.
- Arms** : Double-sided. Ø40 mm x 2 mm 304-grade stainless steel (Opt. 316 - grade stainless steel).
- Body Features** : 304-grade (Opt. 316-grade) stainless steel with brushed (Opt. satin) surface .
- Operation Temperature, Humidity, IP Rating, MCBF** : -20°C to +68°C (Opt. -50°C with heater unit), RH 95% non-condensig / IP 54 outdoor model (Opt. IP 56) / 1M cycles
- Control System** : All inputs are opto-coupler protected. Compatible with all access control systems that provide dry contact or grounding outputs. Optional RS232/RS485/TCP IP control module is available.
- Operation** : Manually operated bi-directional system (optional motorized) with dip switch selectable operational modes including controlled access on both sides, one side free (exit or entry) and other side controlled access and access restriction modes.
- Emergency Mode** : System allows free passage in emergency mode and in case of power failure.
- Flow Rate** : Capacity of mechanism (manual system): max. 97 + 97 passages/minute, nominal: ~20 + ~20 passages/minute
Capacity of mechanism (motorized system): max. 48 + 48 passages/minute, nominal: ~16 + ~16 passages/minute
- Standard Features** : Direction and status indicators on top and sides.
- Optional Accessories and Applications** : Remote control units, interface unit for PC, RS485, RS232 and LAN, counter, audio-messaging system, motor driven unit, automatic drop (retractable) arm, alarm sensor, heater positive unit, coin slot/intelligent coin system and coin box, card reader pole, pipe barrier (separator), floor mounting plate, customised top covers to accommodate various accessories.

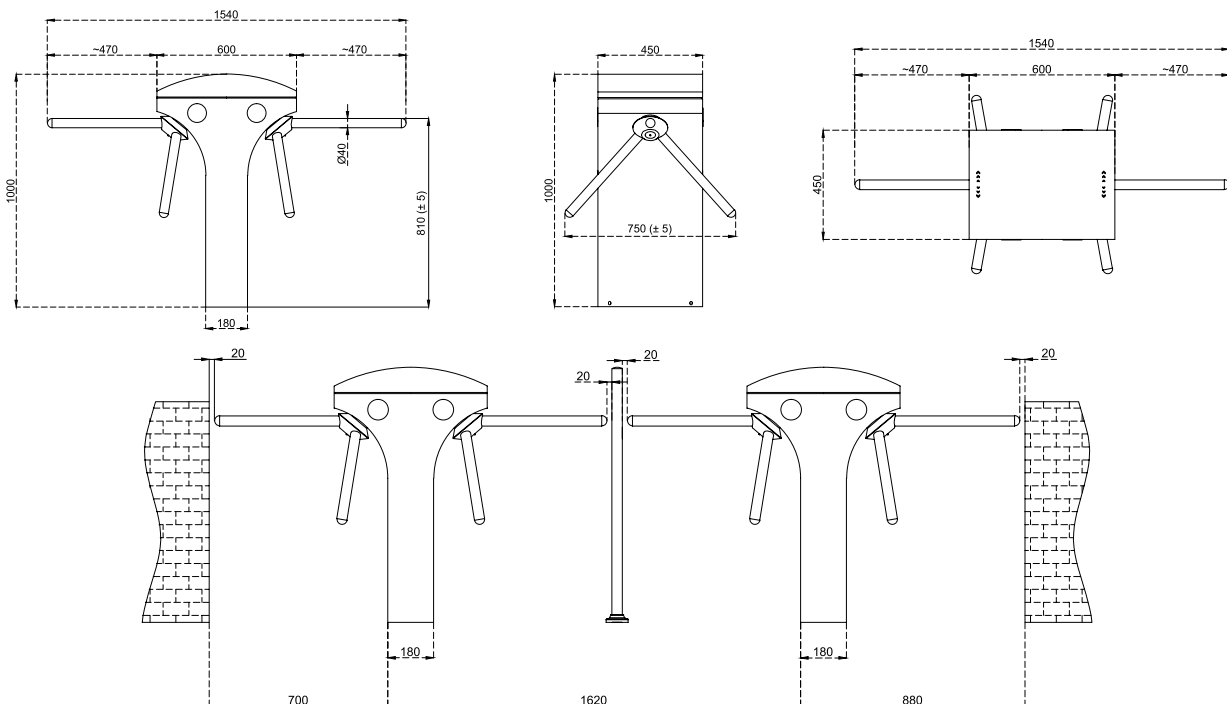

*Design and specifications are subject to change without notice. *All dimensions are in mm.



500 E



- Power Requirements** : 110/220-240 V. 60/50 Hz. AC (%±10) 24 V. DC at standby ~4,4 W. max. ~12 W.
- Arms** : Ø40 mm x 2 mm 304-grade stainless steel (Opt. 316 - grade stainless steel).
- Body Features** : 304-grade (Opt. 316-grade) stainless steel with brushed (Opt. satin) surface.
- Operation Temperature, Humidity, IP Rating, MCBF** : -20°C to +68°C (Opt. -50°C with heater unit), RH 95% non-condensing / IP 54 outdoor model (Opt. IP 56) / 1M cycles.
- Control System** : All inputs are opto-coupler protected. Compatible with all access control systems that provide dry contact or grounding outputs. Optional RS232/RS485/TCP IP control module is available.
- Operation** : Manually operated bi-directional system (optional motorized) with dip switch selectable operational modes including controlled access on both sides, one side free (exit or entry) and other side controlled access and access restriction modes.
- Emergency Mode** : System allows free passage in emergency mode and in case of power failure.
- Flow Rate** : Capacity of mechanism (manual system): max. 97 passages/minute, nominal: ~20 passages/minute
Capacity of mechanism (motorized system): max. 48 passages/minute, nominal: ~16 passages/minute
- Standard Features** : Direction and status indicators.
- Optional Accessories and Applications** : Remote control units, interface unit for PC, RS485, RS232 and LAN, counter, audio-messaging system, motor driven unit, automatic drop (retractable) arm, alarm sensor, heater positive unit, coin slot/intelligent coin system and coin box, card reader pole, pipe barrier (separator), floor mounting plate, top passage indicators, customised top covers to accommodate various accessories.

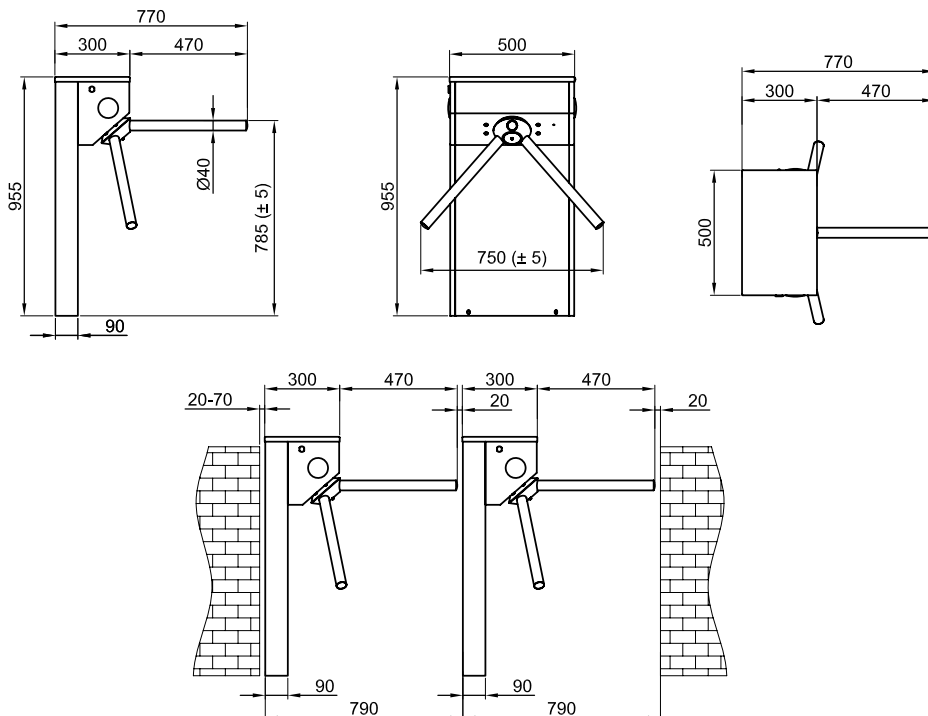

**Design and specifications are subject to change without notice. *All dimensions are in mm.*

500 E D

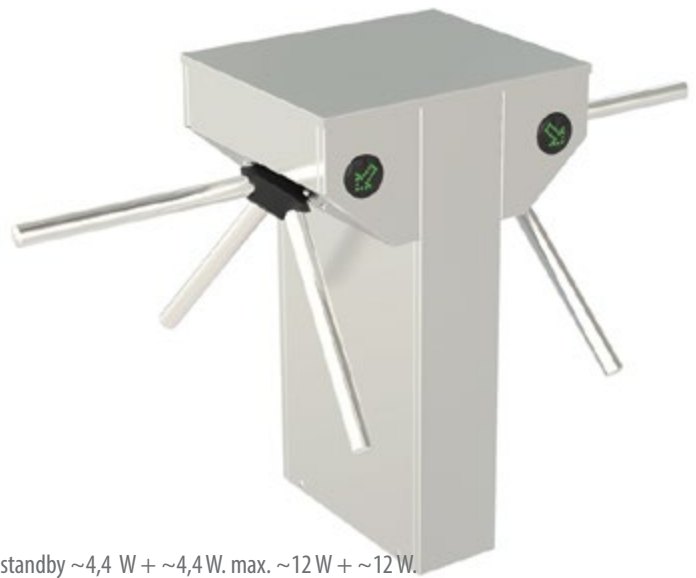

- Power Requirements** : 110/220-240 V. 60/50 Hz. AC (%±10) 24V. DC at standby ~4,4 W + ~4,4 W. max. ~12 W + ~12 W.
- Arms** : Double-sided. Ø40 mm x 2 mm 304-grade stainless steel (Opt. 316 - grade stainless steel).
- Body Features** : 304-grade stainless steel with brushed (Opt. satin) surface.
- Operation Temperature, Humidity, IP Rating, MCBF** : -20°C to +68°C (Opt. -50°C with heater unit), RH 95% non-condensing / IP 54 outdoor model (Opt. IP 56) / 1M cycles.
- Control System** : All inputs are opto-coupler protected. Compatible with all access control systems that provide dry contact or grounding outputs. Optional RS232/RS485/TCP IP control module is available.
- Operation** : Manually operated bi-directional system (optional motorized) with dip switch selectable operational modes including controlled access on both sides, one side free (exit or entry) and other side controlled access and access restriction modes.
- Emergency Mode** : System allows free passage in emergency mode and in case of power failure.
- Flow Rate** : Capacity of mechanism (manual system): max. 97 + 97 passages/minute, nominal: ~20 + ~20 passages/minute
Capacity of mechanism (motorized system): max. 48 + 48 passages/minute, nominal: ~16 + ~16 passages/minute
- Standard Features** : Direction and status indicators.
- Optional Accessories and Applications** : Remote control units, interface unit for PC, RS485, RS232 and LAN, counter, audio-messaging system, motor driven unit, automatic drop (retractable) arm, alarm sensor, heater positive unit, coin slot/intelligent coin system and coin box, card reader pole, pipe barrier (separator), floor mounting plate, top passage indicators, customised top covers to accommodate various accessories.

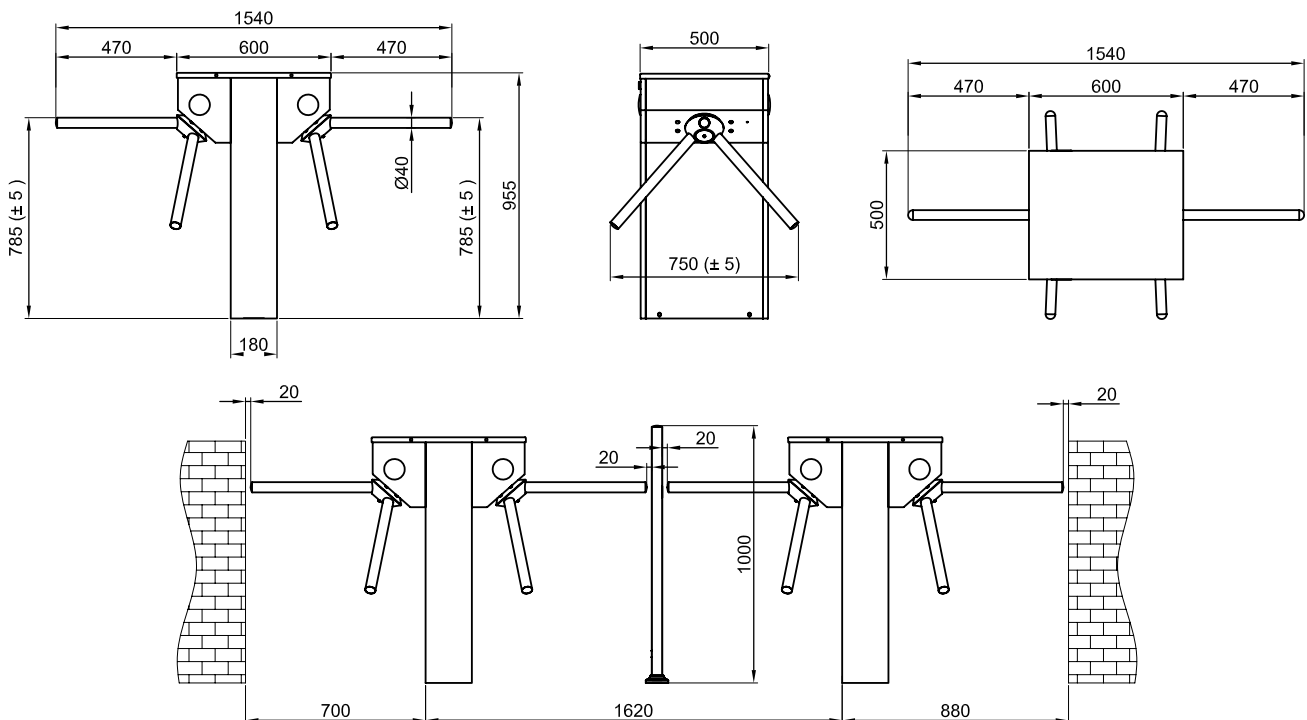

*Design and specifications are subject to change without notice. *All dimensions are in mm.



FKR 777



- Power Requirements** : 110/220-240 V. 60/50 Hz. AC (%±10) 24V. DC at standby ~4,5 W. max. ~13 W.
- Arms** : Three Ø40 mm transparent acrylic arms (Opt. 304 or 316 - grade stainless steel).
- Body Features** : The natural granite (Star Galaxy Black) stone (20 mm thickness) on top is a standard feature for a decorative and aesthetical appearance. Lower body is made of Art-Line design semi-transparent layered dark grey acrylic panels.
- Operation Temperature, Humidity, IP Rating, MCBF** : -20°C to +68°C / RH 95% non-condensing / IP 44 indoor model / 1M cycles
- Control System** : All inputs are opto-coupler protected. Compatible with all access control systems that provide dry contact or grounding outputs. Optional RS232/RS485/TCP IP control module is available.
- Operation** : Manually operated bi-directional system (optional motorized) with dip switch selectable operational modes including controlled access on both sides, one side free (exit or entry) and other side controlled access and access restriction modes.
- Emergency Mode** : System allows free passage in emergency mode and in case of power failure.
- Flow Rate** : Capacity of mechanism (manual system): max. 97 passages/minute, nominal: ~20 passages/minute
Capacity of mechanism (motorized system): max. 48 passages/minute, nominal: ~16 passages/minute
- Standard Features** : Direction and status indicators on top and sides.
- Optional Accessories and Applications** : Remote control units, interface unit for PC, RS485, RS232 and LAN, counter, audio-messaging system, motor driven unit, alarm sensor, heater positive unit, coin slot/intelligent coin system and coin box, card reader pole, pipe barrier (separator), floor mounting plate, choice of different top lid materials.

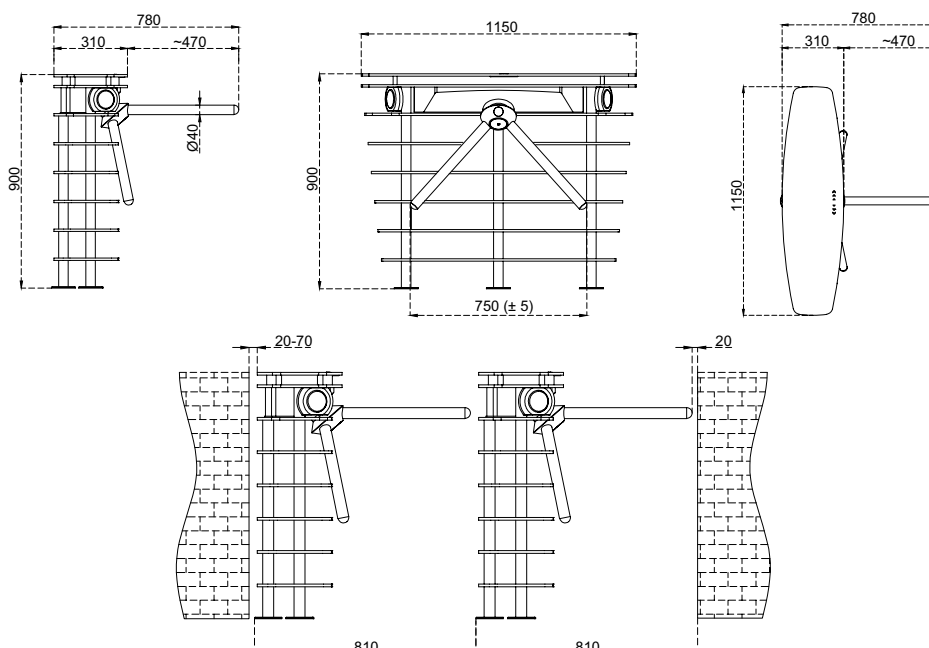

*Design and specifications are subject to change without notice. *All dimensions are in mm.

702 R N1



- Power Requirements** : 110/220-240 V. 60/50 Hz. AC (%±10) 24 V. DC at standby ~17 W. max. ~40 W.
- Arms** : Automatic drop (retractable) arm Ø40 mm x 1,2 mm 304-grade stainless steel (Opt. 316 - grade stainless steel).
- Body Features** : 304-grade (Opt. 316-grade) stainless steel with brushed (Opt. satin) surface.
- Operation Temperature, Humidity, IP Rating, MCBF** : -20°C to +68°C (-50°C with optional heater unit), RH 95% non-condensing / IP 54 outdoor model (Opt. IP 56) / 1M cycles
- Control System** : All inputs are opto-coupler protected. Compatible with all access control systems that provide dry contact or grounding output. Optional RS232/RS485/TCP IP control module is available.
- Operation** : Motorized (Opt. Manual System) bi-directional passage system with dip switch selectable operational modes including controlled access on both sides, one side free (exit or entry) and other side controlled access and access restriction modes.; the system unlocks upon receiving input and motor is activated by a gentle push on the arm to allow passage.
- Emergency Mode** : Automatic drop arm retracts and system allows free passage in emergency mode and in case of power failure.
- Flow Rate** : Capacity of mechanism (manual system): max. 97 passages/minute, nominal: ~20 passages/minute
Capacity of mechanism (motorized system): max. 48 passages/minute, nominal: ~16 passages/minute
- Standard Features** : Direction and status indicators on top and sides, motorized mechanism, retractable arms.
- Optional Accessories and Applications** : Remote control units, interface unit for PC, RS485, RS232 and LAN, counter, audio-messaging system, alarm sensor, heater positive unit, coin slot/intelligent coin system and coin box, card reader pole, pipe barrier (separator), floor mounting plate, manual mechanics, customised top covers to accommodate various accessories.

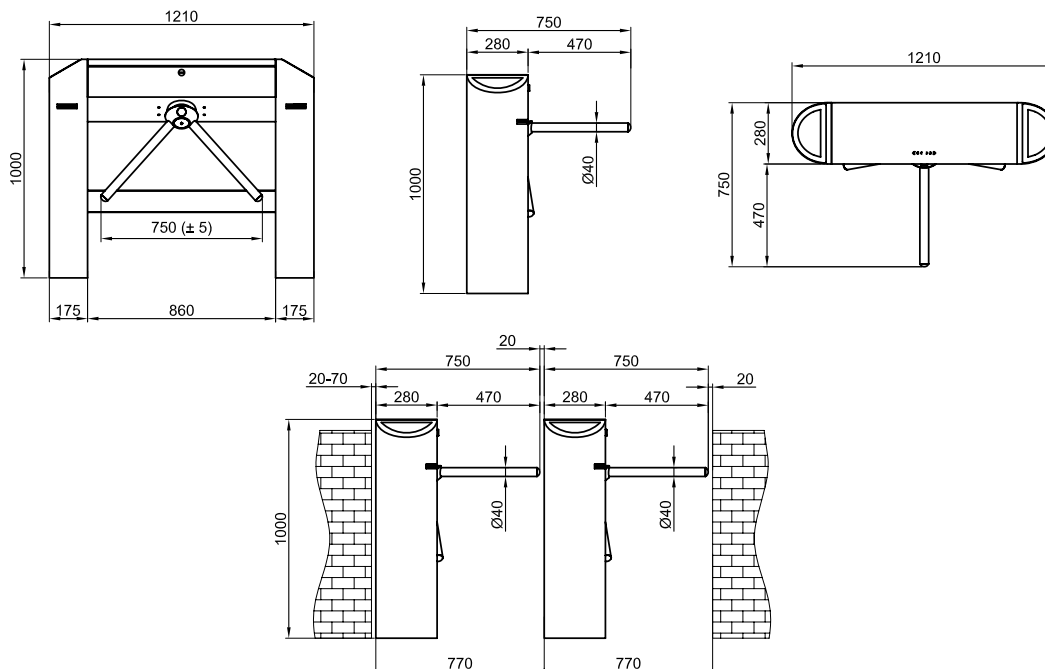

**Design and specifications are subject to change without notice. *All dimensions are in mm.*



700 R



- Power Requirements** : 110/220-240 V. 60/50 Hz. AC (%±10) 24V. DC at standby ~4,4 W. max. ~12 W.
- Arms** : Ø40 mm x 2 mm 304-grade stainless steel (Opt. 316 - grade stainless steel).
- Body Features** : 304-grade (Opt. 316-grade) stainless steel with brushed (Opt. satin) surface with aesthetic round corners.
- Operation Temperature, Humidity, IP Rating, MCBF** : -20°C to +68°C (Opt. -50°C with heater unit), RH 95% non-condensing / IP 54 outdoor model (Opt. IP 56) / 1M cycles
- Control System** : All inputs are opto-coupler protected. Compatible with all access control systems that provide dry contact or grounding outputs. Optional RS232/RS485/TCP IP control module is available.
- Operation** : Manually operated bi-directional system (optional motorized) with dip switch selectable operational modes including controlled access on both sides, one side free (exit or entry) and other side controlled access and access restriction modes.
- Emergency Mode** : System allows free passage in emergency mode and in case of power failure.
- Flow Rate** : Capacity of mechanism (manual system): max. 97 passages/minute, nominal: ~20 passages/minute
Capacity of mechanism (motorized system): max. 48 passages/minute, nominal: ~16 passages/minute
- Standard Features** : Direction and status indicators
- Optional Accessories and Applications** : Remote control units, interface unit for PC, RS485, RS232 and LAN, counter, audio-messaging system, motor driven unit, automatic drop (retractable) arm, alarm sensor, heater positive unit, coin slot/intelligent coin system and coin box, card reader pole, pipe barrier (separator), floor mounting plate, top passage indicators, customised top covers to accommodate various accessories.

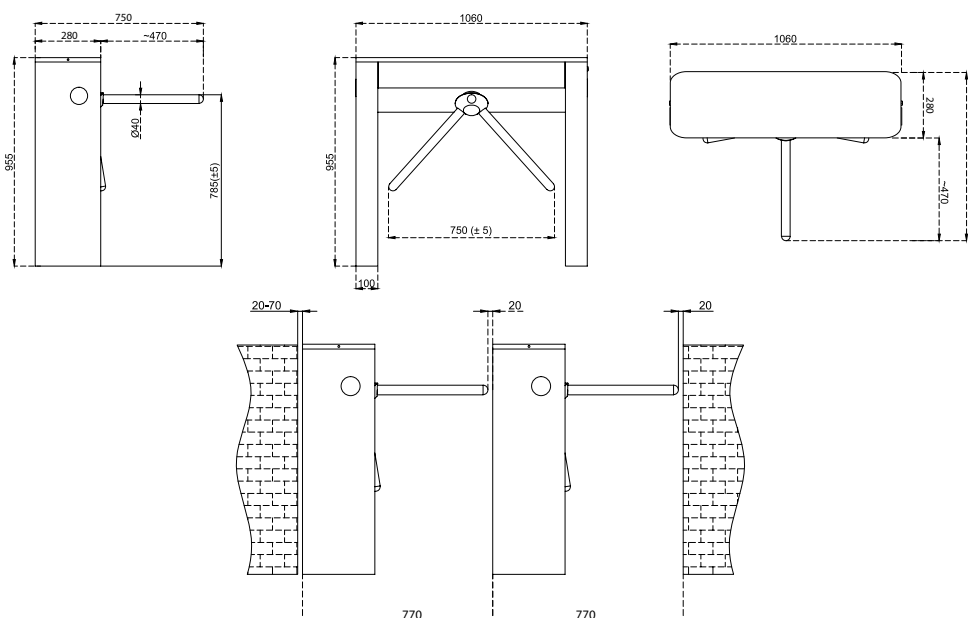

*Design and specifications are subject to change without notice. *All dimensions are in mm.

METROPORT

RESIDENCE

METROPORT

BUSINESS





700 E N1



- Power Requirements** : 110/220-240 V. 60/50 Hz. AC (%±10) 24V. DC at standby ~4,4 W. max. ~12 W.
- Arms** : Ø40 mm x 2 mm 304-grade stainless steel (Opt. 316 - grade stainless steel).
- Body Features** : 304-grade (Opt. 316-grade) stainless steel with brushed (Opt. satin) surface.
- Operation Temperature, Humidity, IP Rating, MCBF** : -20°C to +68°C (Opt. -50°C with heater unit), RH 95% non-condensing / IP 54 outdoor model (Opt. IP 56) / 1M cycles
- Control System** : All inputs are opto-coupler protected. Compatible with all access control systems that provide dry contact or grounding outputs. Optional RS232/RS485/TCP IP control module is available.
- Operation** : Manually operated bi-directional system (optional motorized) with dip switch selectable operational modes including controlled access on both sides, one side free (exit or entry) and other side controlled access and access restriction modes.
- Emergency Mode** : System allows free passage in emergency mode and in case of power failure.
- Flow Rate** : Capacity of mechanism (manual system): max. 97 passages/minute, nominal: ~20 passages/minute
Capacity of mechanism (motorized system): max. 48 passages/minute, nominal: ~16 passages/minute
- Standard Features** : Direction and status indicators.
- Optional Accessories and Applications** : Remote control units, interface unit for PC, RS485, RS232 and LAN, counter, audio-messaging system, motor driven unit, automatic drop (retractable) arm, alarm sensor, heater positive unit, coin slot/intelligent coin system and coin box, card reader pole, pipe barrier (separator), floor mounting plate, top passage indicators, customised top covers to accommodate various accessories.

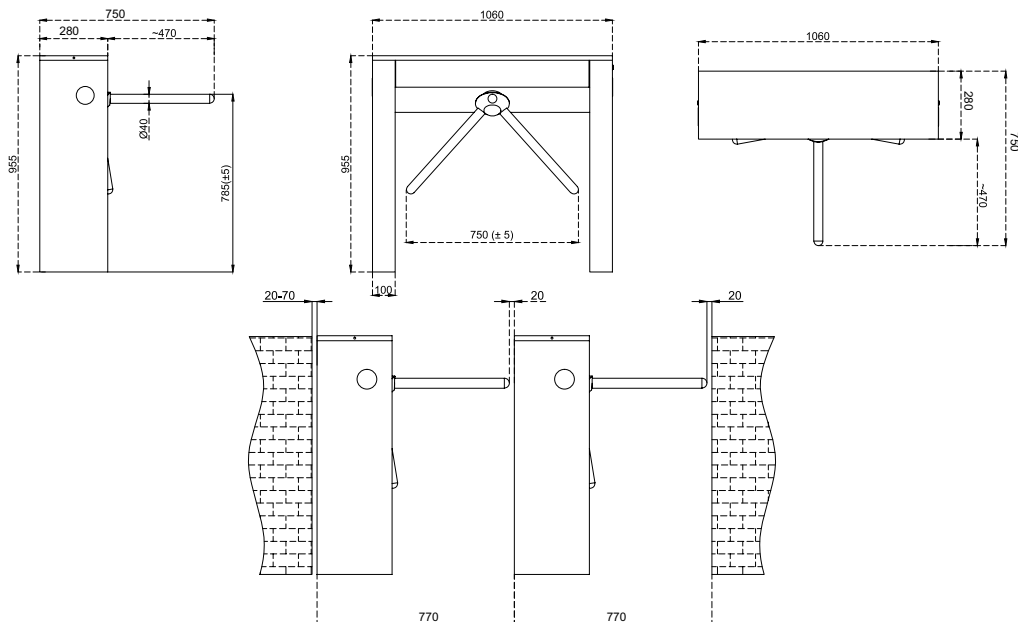

**Design and specifications are subject to change without notice. *All dimensions are in mm.*

700 E D N1



- Power Requirements** : 110/220-240 V. 60/50 Hz. AC (%±10) 24 V. DC at standby ~4,4 W + ~4,4 W. max. ~12 W + ~12 W.
- Arms** : Double-Sided. Ø40 mm x 2 mm 304-grade stainless steel (Opt. 316 - grade stainless steel).
- Body Features** : 304-grade (Opt. 316-grade) stainless steel with brushed (Opt. satin) surface.
- Operation Temperature, Humidity, IP Rating, MCBF** : -20° C to +68° C (Opt. -50° C with heater unit), RH 95% non-condensing / IP 54 outdoor model (Opt. IP 56) / 1M cycles.
- Control System** : All inputs are opto-coupler protected. Compatible with all access control systems that provide dry contact or grounding outputs. Optional RS232/RS485/TCP IP control module is available.
- Operation** : Manually operated bi-directional system (optional motorized) with dip switch selectable operational modes including controlled access on both sides, one side free (exit or entry) and other side controlled access and access restriction modes.
- Emergency Mode** : System allows free passage in emergency mode and in case of power failure.
- Flow Rate** : Capacity of mechanism (manual system): max. 97 + 97 passages/minute, nominal: ~20 + ~20 passages/minute
Capacity of mechanism (motorized system): max. 48 + 48 passages/minute, nominal: ~16 + ~16 passages/minute
- Standard Features** : Direction and status indicators.
- Optional Accessories and Applications** : Remote control units, interface unit for PC, RS485, RS232 and LAN, counter, audio-messaging system, motor driven unit, automatic drop (retractable) arm, alarm sensor, heater positive unit, coin slot/intelligent coin system and coin box, card reader pole, pipe barrier (separator), floor mounting plate, top passage indicators, customised top covers to accommodate various accessories.

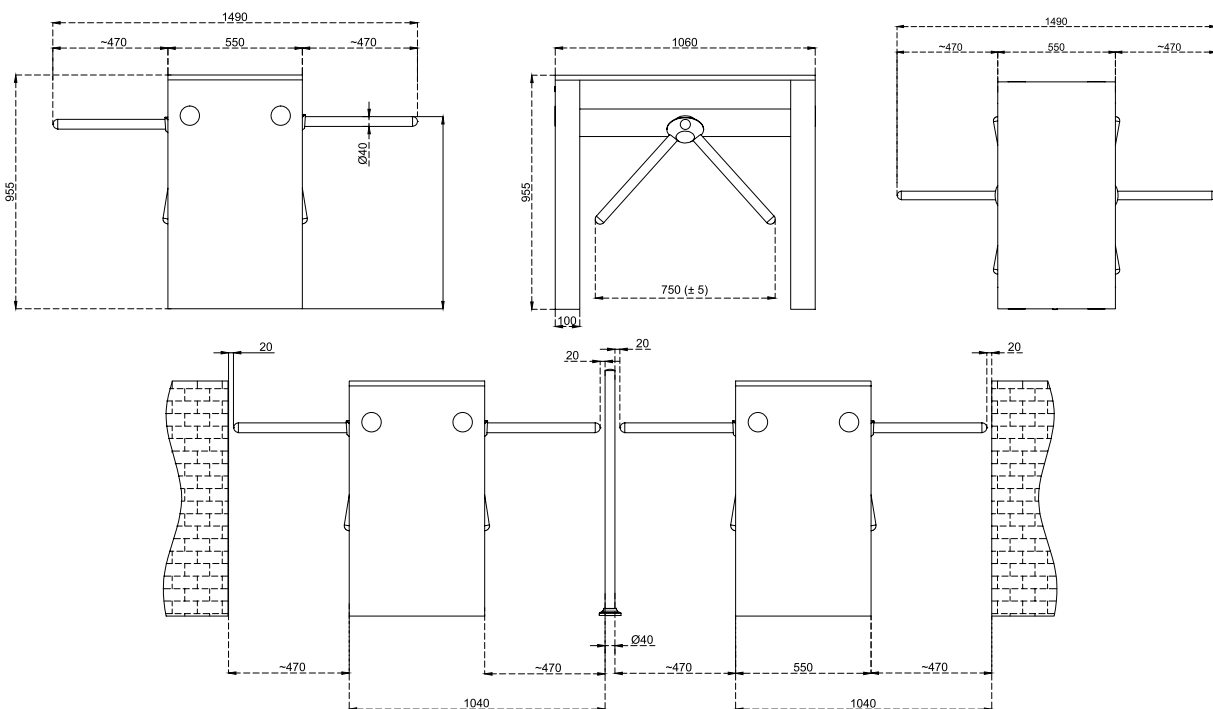

**Design and specifications are subject to change without notice. *All dimensions are in mm.*





Waist Height Turnstiles
Turnstiles for Reduced Mobility

605



- Power Requirements** : 110/220-240 V. 60/50 Hz. AC (%±10) 24V. DC at standby ~7,5 W. max. ~27,4 W.
- Wing Features** : Available in 450 or 900 mm standard lengths. Ø33,7 mm x 1,5 mm 304-grade stainless steel wing frame with acrylic panel.
- Body Features** : 304-grade (Opt. 316-grade) stainless steel brushed (Opt. satin) surface.
- Operation Temperature, Humidity, IP Rating, MCBF** : -20°C to +68°C (Opt. -50°C with heater unit), RH 95% non-condensing / IP 54 outdoor model (Opt. IP 56) / 1M cycles
- Control System** : All inputs are opto-coupler protected. Compatible with all access control systems that provide dry contact or grounding outputs. Optional RS232/RS485/TCP IP control module is available.
- Operation** : Electronically controlled DC motor driven bi-directional system.
- Emergency Mode** : System allows free passage in emergency mode and in case of power failure.
- Flow Rate** : Wing opening / closing time ~1,5 - 2,5 sec.
- Standard Features** : Direction and status indicators on top and sides.
- Optional Accessories and Applications** : Remote control units, interface unit for PC, RS485, RS232 and LAN, counter, audio-messaging system, alarm sensor, heater positive unit, coin slot/intelligent coin system and coin box, card reader pole, pipe barrier (separator), floor mounting plate.

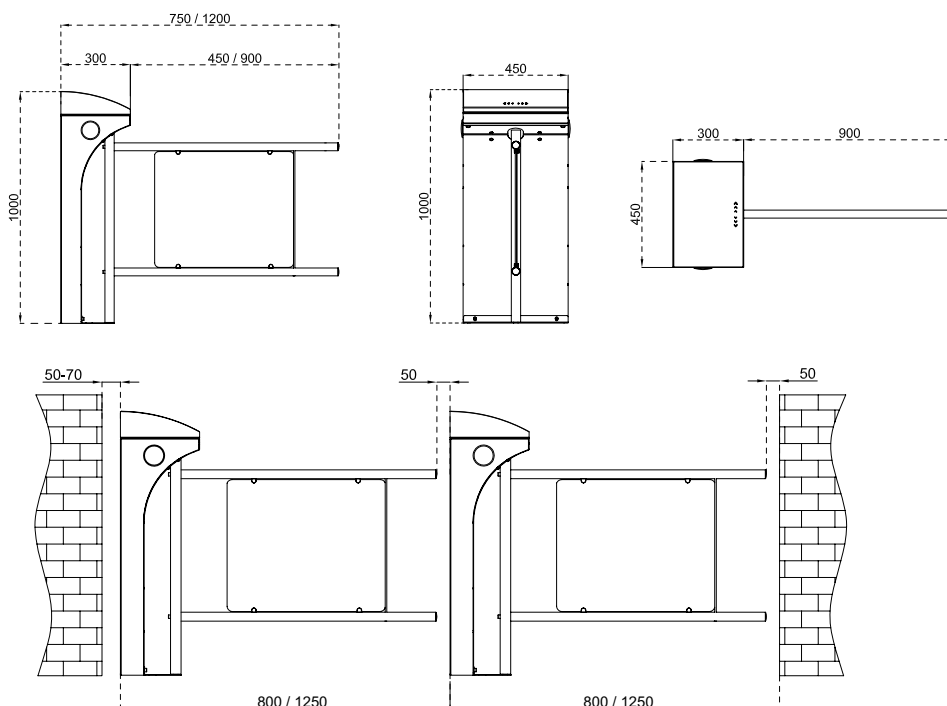

**Design and specifications are subject to change without notice. *All dimensions are in mm.*

605 D



- Power Requirements** : 110/220-240 V. 60/50 Hz. AC (± 10) 24 V. DC at standby $\sim 7,5$ + $\sim 7,5$ W. max. $\sim 27,4$ + $\sim 27,4$ W.
- Wing Features** : Double-sided. Available in 450 or 900 mm standard lengths. $\varnothing 33,7$ mm x 1,5 mm 304-grade stainless steel wing frame with acrylic panel.
- Body Features** : 304-grade (Opt. 316-grade) stainless steel brushed (Opt. satin) surface.
- Operation Temperature, Humidity, IP Rating, MCBF** : -20°C to $+68^{\circ}\text{C}$ (Opt. -50°C with heater unit), RH 95% non-condensing / IP 54 outdoor model (Opt. IP 56) / 1M cycles.
- Control System** : All inputs are opto-coupler protected. Compatible with all access control systems that provide dry contact or grounding outputs. Optional RS232/RS485/TCP IP control module is available.
- Operation** : Electronically controlled DC motor driven bi-directional system.
- Emergency Mode** : System allows free passage in emergency mode and in case of power failure.
- Flow Rate** : Wing opening / closing time $\sim 1,5$ - 2,5 sec.
- Standard Features** : Direction and status indicators on top and sides.
- Optional Accessories and Applications** : Remote control units, interface unit for PC, RS485, RS232 and LAN, counter, audio-messaging system, alarm sensor, heater positive unit, coin slot/intelligent coin system and coin box, card reader pole, pipe barrier (separator), floor mounting plate.

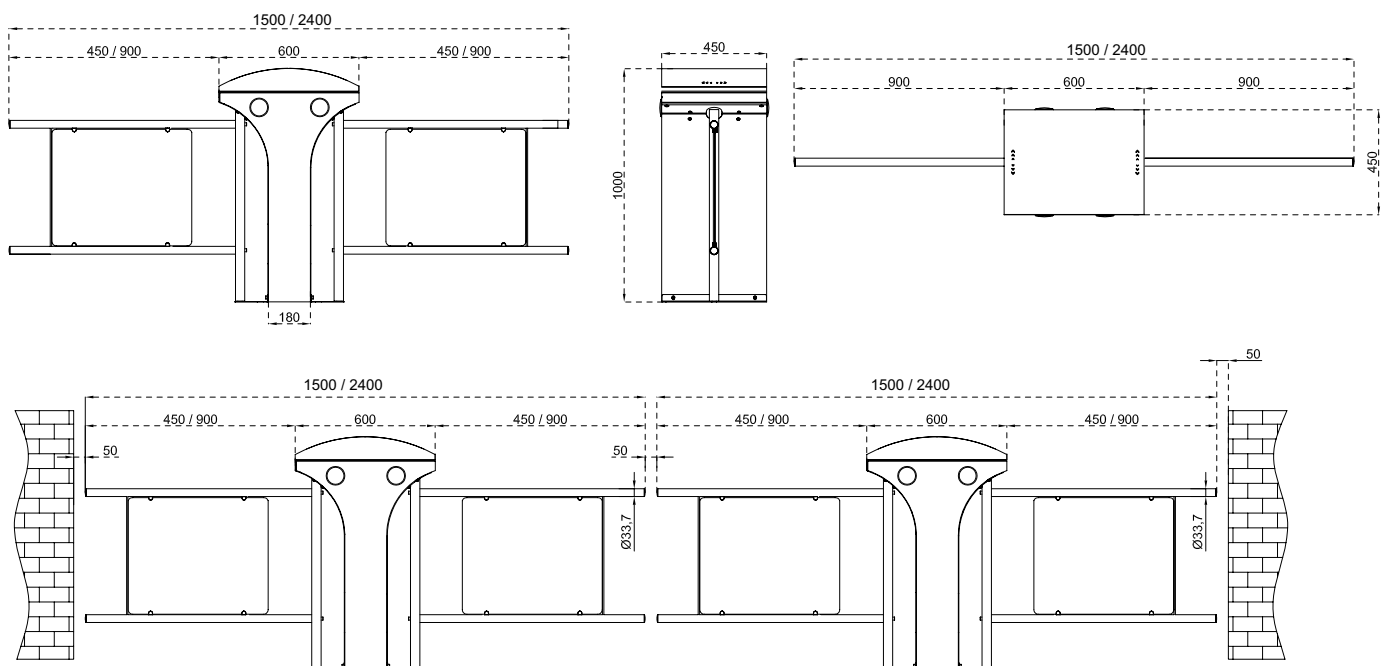



705 E N1



- Power Requirements** : 110/220-240 V. 60/50 Hz. AC (%±10) 24V. DC at standby ~7,5 W. max. ~27,4 W.
- Wing Features** : Available in 450 or 900 mm standard lengths. Ø33,7 mm x 1,5 mm 304-grade stainless steel wing frame with acrylic panel.
- Body Features** : 304-grade (Opt. 316-grade) stainless steel brushed (Opt. satin) surface.
- Operation Temperature, Humidity, IP Rating, MCBF** : -20°C to +68°C (Opt. -50°C with heater unit), RH 95% non-condensing / IP 54 outdoor model (Opt. IP 56) / 1M cycles
- Control System** : All inputs are opto-coupler protected. Compatible with all access control systems that provide dry contact or grounding outputs. Optional RS232/RS485/TCP IP control module is available.
- Operation** : Electronically controlled DC motor driven bi-directional system.
- Emergency Mode** : System allows free passage in emergency mode and in case of power failure.
- Flow Rate** : Wing opening / closing time ~1,5 - 2,5 sec.
- Standard Features** : Direction and status indicators.
- Optional Accessories and Applications** : Remote control units, interface unit for PC, RS485, RS232 and LAN, counter, audio-messaging system, alarm sensor, heater positive unit, coin slot/intelligent coin system and coin box, card reader pole, pipe barrier (separator), top passage indicators, floor mounting plate.

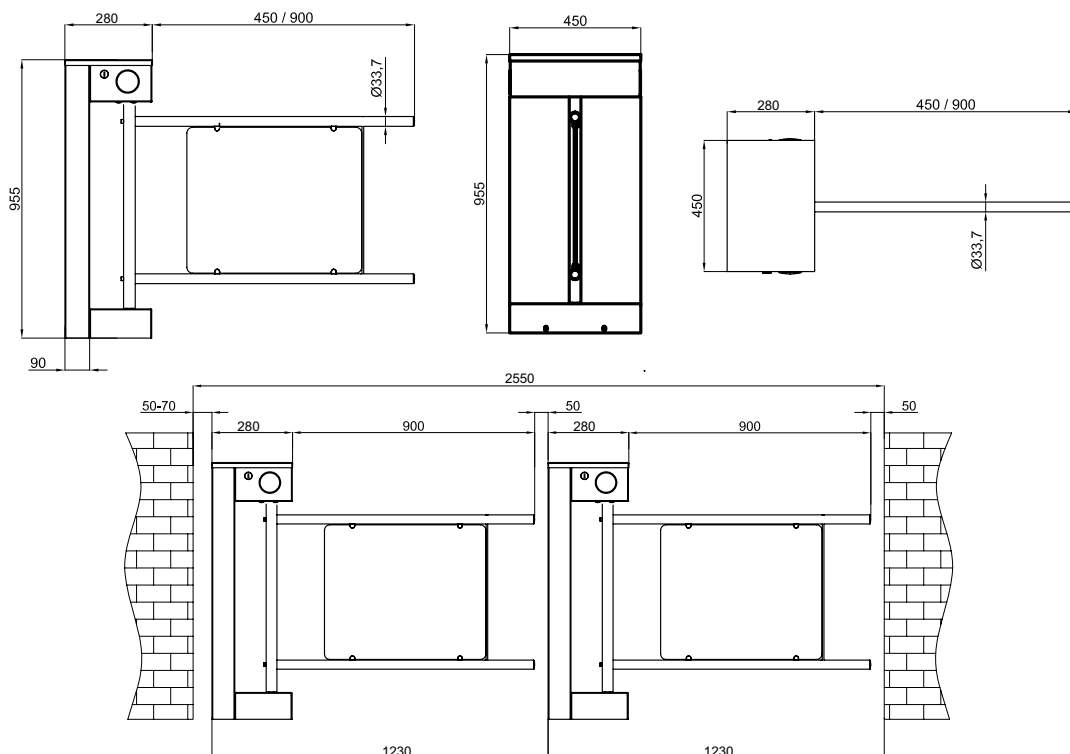

**Design and specifications are subject to change without notice. *All dimensions are in mm.*

705 E D N1



- Power Requirements** : 110/220-240 V. 60/50 Hz. AC (%±10) 24 V. DC at standby ~7,5 + ~7,5 W. max. ~27,4 + ~27,4 W.
- Wing Features** : Double-sided. Available in 450 or 900 mm standard lengths. Ø33,7 mm x 1,5 mm 304-grade stainless steel wing frame with acrylic panel.
- Body Features** : 304-grade (Opt. 316-grade) stainless steel brushed (Opt. satin) surface.
- Operation Temperature, Humidity, IP Rating, MCBF** : -20°C to +68°C (Opt. -50°C with heater unit), RH 95% non-condensing / IP 54 outdoor model (Opt. IP 56) / 1M cycles
- Control System** : All inputs are opto-coupler protected. Compatible with all access control systems that provide dry contact or grounding outputs. Optional RS232/RS485/TCP IP control module is available.
- Operation** : Electronically controlled DC motor driven bi-directional system.
- Emergency Mode** : System allows free passage in emergency mode and in case of power failure.
- Flow Rate** : Wing opening / closing time ~1,5 - 2,5 sec.
- Standard Features** : Direction and status indicators.
- Optional Accessories and Applications** : Remote control units, interface unit for PC, RS485, RS232 and LAN, counter, audio-messaging system, alarm sensor, heater positive unit, coin slot/intelligent coin system and coin box, card reader pole, pipe barrier (separator), top passage indicators, floor mounting plate.

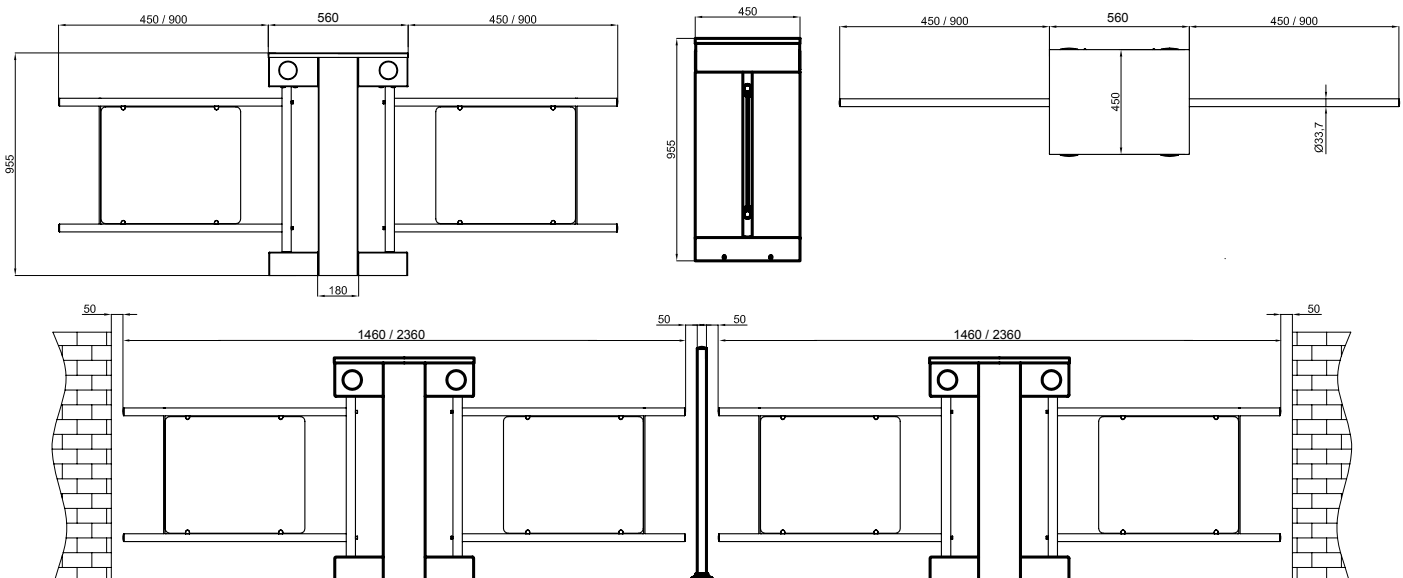





Waist Height Turnstiles
Free Passage Turnstiles



SWG 101



- Power Requirements :** None (standard version)
For electromagnetic lock version: 24 V DC. (250 mA).
- Wing Features :** Ø25 x 2 mm wing flap welded at one point 304-grade stainless steel.
- Body Features :** Ø89 x 3 mm 304-grade (Opt. 316-grade) stainless steel.
- System Features :** Manually operated unidirectional, push to open (90° - clockwise or counter clockwise), spring loaded return system. For electromagnetic lock version in case of power failure the electromagnetic lock releases the panel for free passage.
- Optional Accessories and Applications :** Electromagnetic Lock with 35 kgf resistance , manual lock, key lock pole, separator.

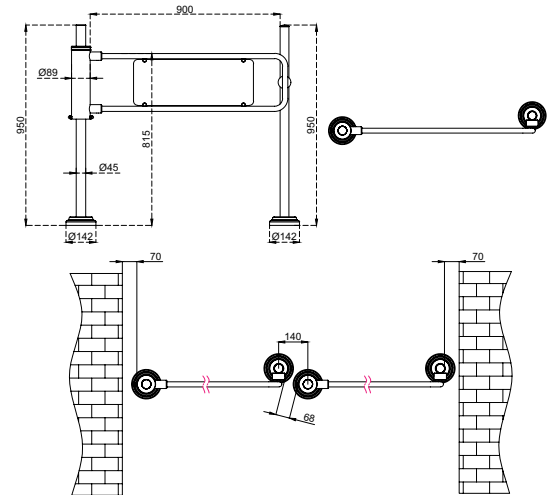

MRKT 404



- Power Requirements :** None.
- Arms :** Ø40 x 2 mm 304 grade stainless steel (Opt. 316 grade stainless steel).
- Body Features :** Ø70 x 2 mm 304-grade (Opt. 316-grade) stainless steel.
- System Features :** Manually operated unidirectional, push to rotate passage.

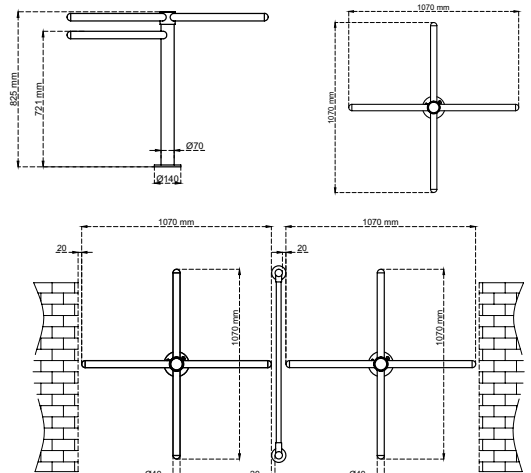



Speed Gates



HG 01



- Power Requirements** : 110/220-240 V. 60/50Hz. AC (%±10) 24V. DC
 Single Unit: At standby~10W. during operation ~39W.
 Center Unit: At standby~20W. during operation ~78W.
- Wing Features** : RGB LED illuminated, 10 mm. thick impact resistant tempered glass (Opt. polycarbon).
- Body Features** : The body is made of 304 grade (Opt. 316-grade) satin finished stainless steel. Natural granite (Star Galaxy Black Pattern) stone on top is standard feature for a decorative and aesthetical appearance. (Opt. materials and patterns available)
- Operation Temperature, Humidity, IP Rating, MCBF** : -20°C to + 68°C / RH 95% non-condensing / IP 44 indoor model / 1M cycles.
- Control System** : All inputs are opto-coupler protected. Compatible with all access control systems that provide dry contact or grounding outputs. Optional RS232/RS485/TCP IP control module is available.
- System Features & Operation** : Electronically controlled rapid wing movement for quick and smooth bi-directional passages. Internal dip switch selectable free passage by photocell detection, restricted access, controlled access on both or single direction modes are built in features.
- Emergency Mode** : System allows free passage in emergency mode and in case of power failure (powered by internal back-up battery).
- Flow Rate** : Wing opening speed/time: 0,5 sec. wing closing speed/time: 0,5 sec.
 Nominal: ~30 - 60 passages/minute (recommended reference figure).
 *Utilisation of different access control units can change the flow rate.
- Standard Features** : Dot matrix direction and status indicators, natural granite top lid, stainless steel and acrylic reader cover plates for both directions.
- Optional Accessories and Applications** : Tempered glass side (lateral) panels, Remote control unit, interface unit for PC, RS485, RS232 and LAN, counter, audio-messaging system, alarm sensor, floor mounting plate, coin slot/intelligent coin system and coin box, separator, card reader pole.
- Note** : A passage lane consists of min. 2 pieces of single units facing each other.

HG 01-S : SINGLE UNIT (LEFT or RIGHT)

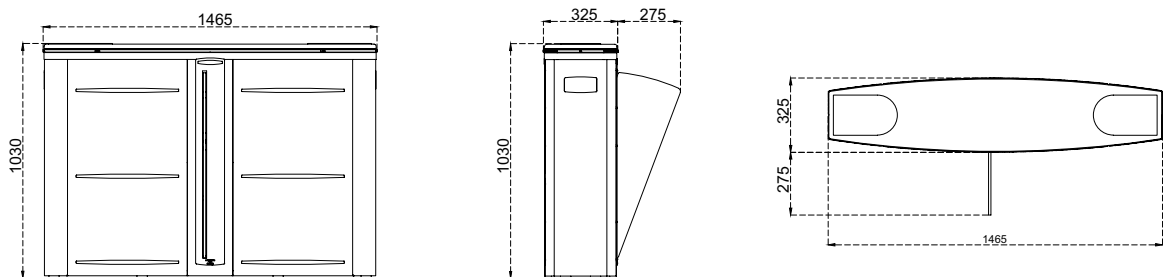

HG 01-C: CENTER UNIT

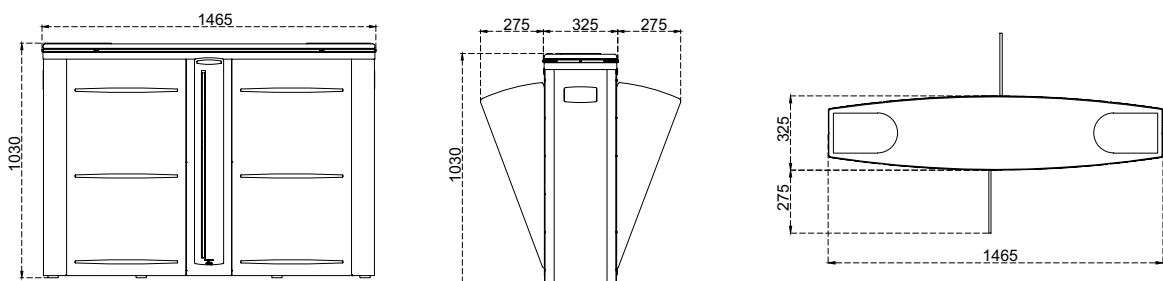

*Design and specifications are subject to change without notice. *All dimensions are in mm.

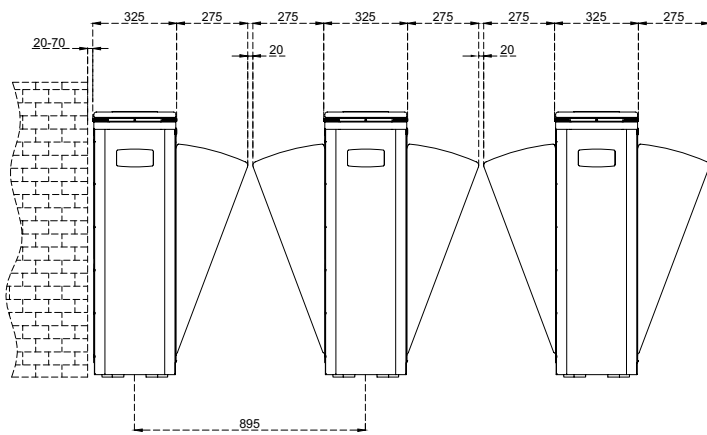
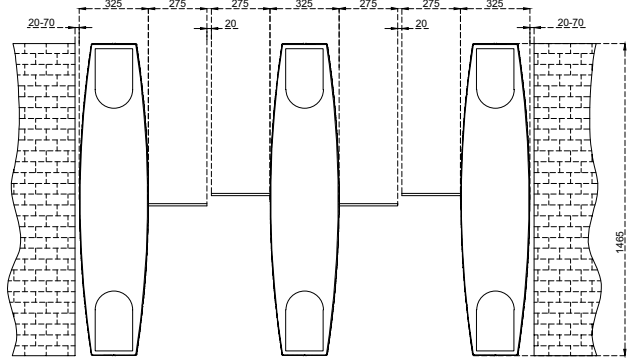
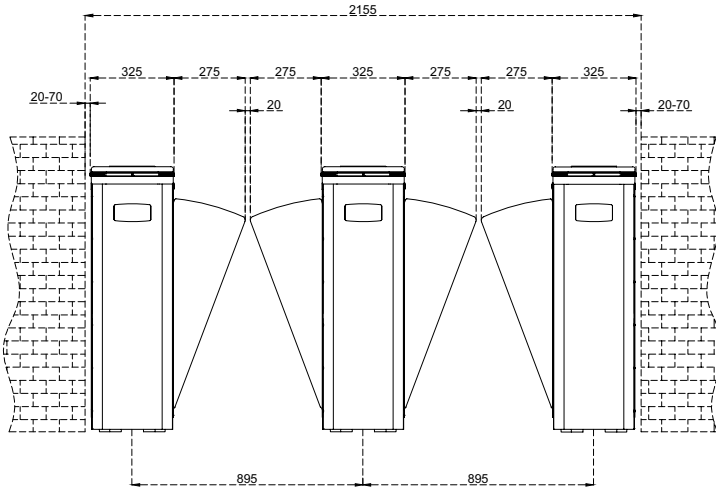
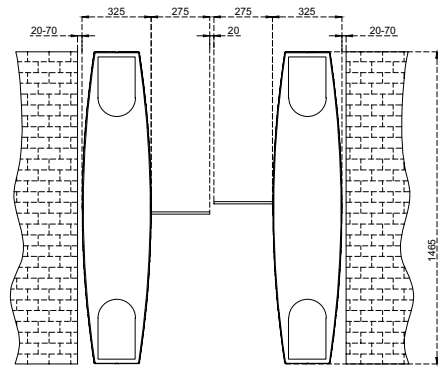
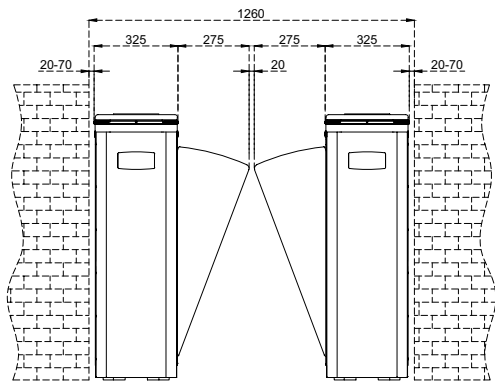

+... n ...+

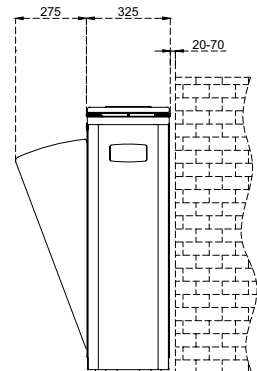



HG 02 GL



- Power Requirements** : 110/220-240 V. 60/50Hz. AC (%±10) 24V. DC
 Single Unit: At standby~10W. During operation ~39W.
 Center Unit: At standby~20W. During operation ~78W.
- Wing Features** : RGB LED illuminated 10mm impact resistant tempered glass (Opt. polycarbon) wings.
- Body Features** : The body is made of 304-grade (Opt. 316-grade) satin finished stainless steel. Tempered glass (Opt. natural granite stone with Star Galaxy Black pattern) on top is standard feature for a decorative and aesthetical appearance (optionally other materials and patterns available).
- Operation Temperature, Humidity, IP Rating, MCBF** : -20°C to + 68°C / RH 95% non-condensing / IP 44 indoor model / 1M cycles.
- Control System** : All inputs are opto-coupler protected. Compatible with all access control systems that provide dry contact or grounding outputs. Optional RS232/RS485/TCP IP control module is available.
- System Features & Operation** : Electronically controlled rapid wing movement for quick and smooth bi-directional passages. Internal dip switch selectable free passage by photocell detection, restricted access, controlled access on both or single direction modes are built in features.
- Emergency Mode** : System allows free passage in emergency mode and in case of power failure (powered by internal back-up battery).
- Flow Rate** : Wing opening speed/Time: 0,5 sec. wing closing speed/time: 0,5 sec.
 Nominal: ~30 - 60 passages/minute (recommended reference figure).
 *Utilisation of different access control units can change the flow rate.
- Standard Features** : RGB LED illuminated status indicators, tempered glass top lid.
- Optional Accessories and Applications** : Tempered glass side (lateral) panels, remote control unit, interface unit for PC, RS485, RS232 and LAN, counter, audio-messaging system, alarm sensor, floor mounting plate, coin slot/intelligent coin system and coin box, separator, card reader pole.
- Note** : A passage lane consists of min. 2 pieces of single units facing each other.

HG 02 GL -S : SINGLE UNIT (LEFT or RIGHT)

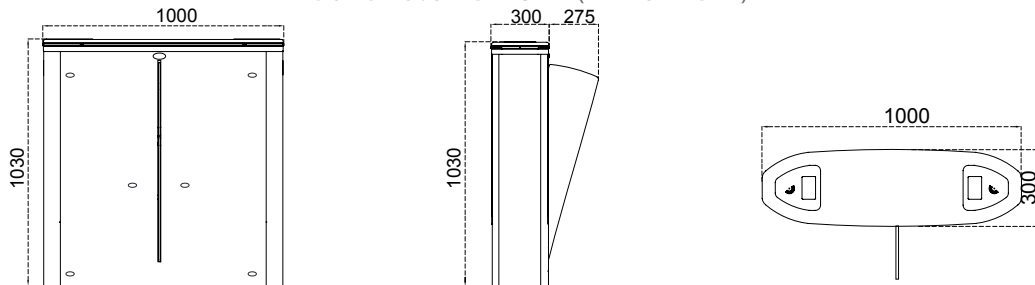

HG 02 GL-C: CENTER UNIT

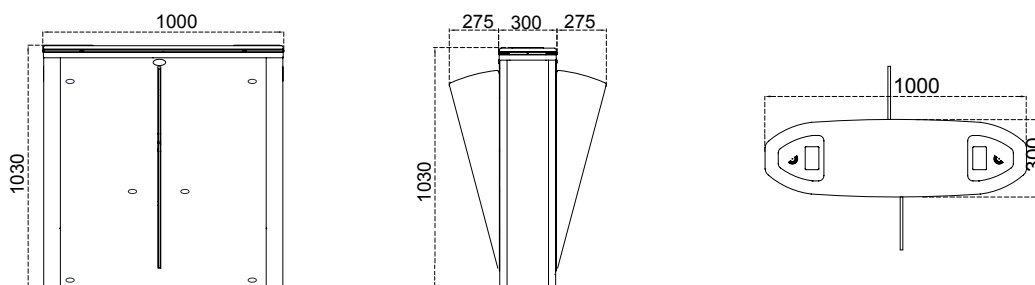

*Design and specifications are subject to change without notice. *All dimensions are in mm.

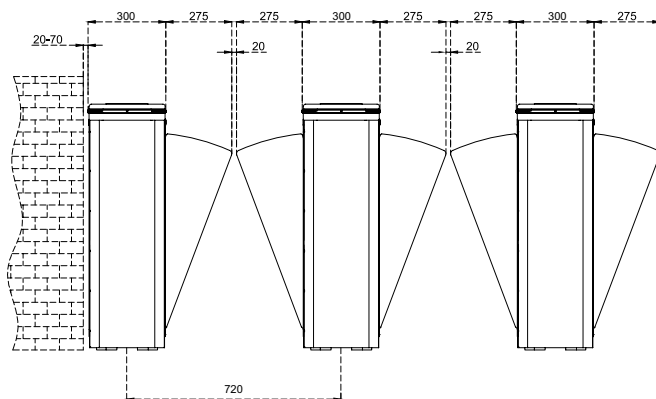
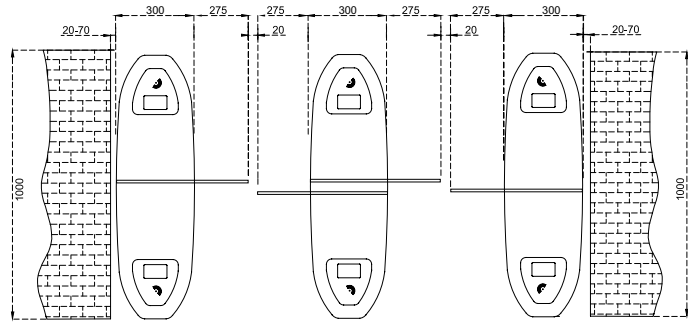
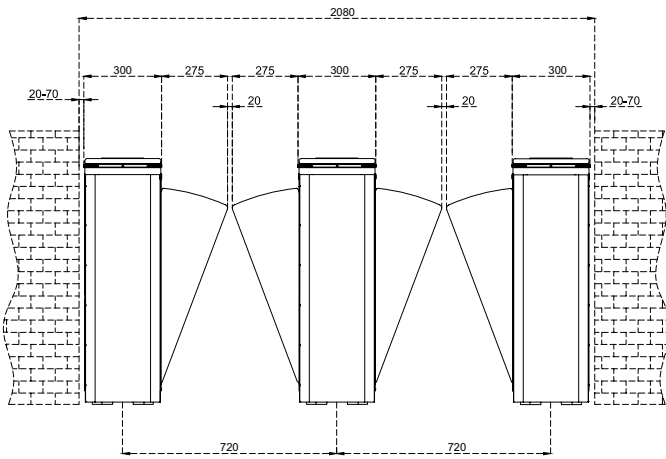
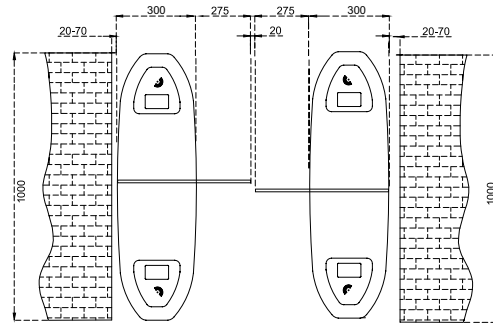
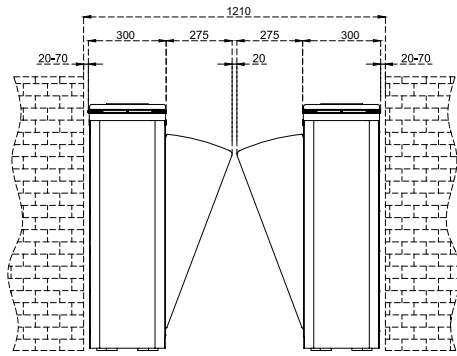

+... n ...+

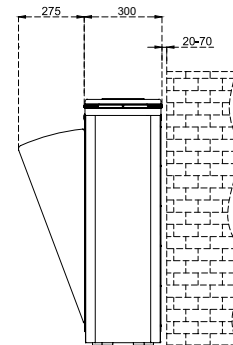





SLIDING GATE 55



Power Requirements

- : 110/220-240V. 60/50 Hz. AC (%±10) 24V. DC
- Single Unit: At standby ~10W. during operation ~39W.
- Center Unit: At standby ~20W. during operation ~78W.

Wing Features

- : RGB LED illuminated 12mm impact resistant tempered glass (Opt. polycarbon) wings.
- Glass wing height options: 900 mm - 1200 mm - 2000 mm in standard.

Body Features

- : The body is made of 304-grade (Opt. 316-grade) satin finished stainless steel. Natural granite (Star Galaxy Black Pattern) stone on top is standard feature for a decorative and aesthetical appearance. (Opt. materials and patterns available).

Operation Temperature, Humidity, IP Rating, MCBF

- : -20°C to + 68°C / RH 95% non-condensing / IP 44 indoor model / 1M cycles.

Control System

- : All inputs are opto-coupler protected. Compatible with all access control systems that provide dry contact or grounding outputs. Optional RS232/RS485/TCP IP control module is available.

System Features & Operation

- : Electronically controlled rapid wing movement for quick and smooth bi-directional passages. Internal dip switch selectable free passage by photocell detection, restricted access, controlled access on both or single direction modes are built in features.

Emergency Mode

- : System allows free passage in emergency mode and in case of power failure (powered by internal back-up battery).

Flow Rate

- : Wing opening speed/time: 0,5 sec. wing closing speed/time: 0,5 sec.
- Nominal: ~30 - 60 passages/minute (recommended reference figure).
- *Utilisation of different access control units can change the flow rate.

Standard Features

- : Dot matrix direction and status indicators, natural granite top lid, stainless steel and acrylic reader cover plates for both directions, luggage trolley passage functionality.

Optional Accessories and Applications

- : Tempered glass side (lateral) panels, remote control unit, interface unit for PC, RS485, RS232 and LAN, counter, audio-messaging system, alarm sensor, floor mounting plate, coin slot/intelligent coin system and coin box, separator, card reader pole.

Note

- : A passage lane consists of min. 2 pieces of single units facing each other.

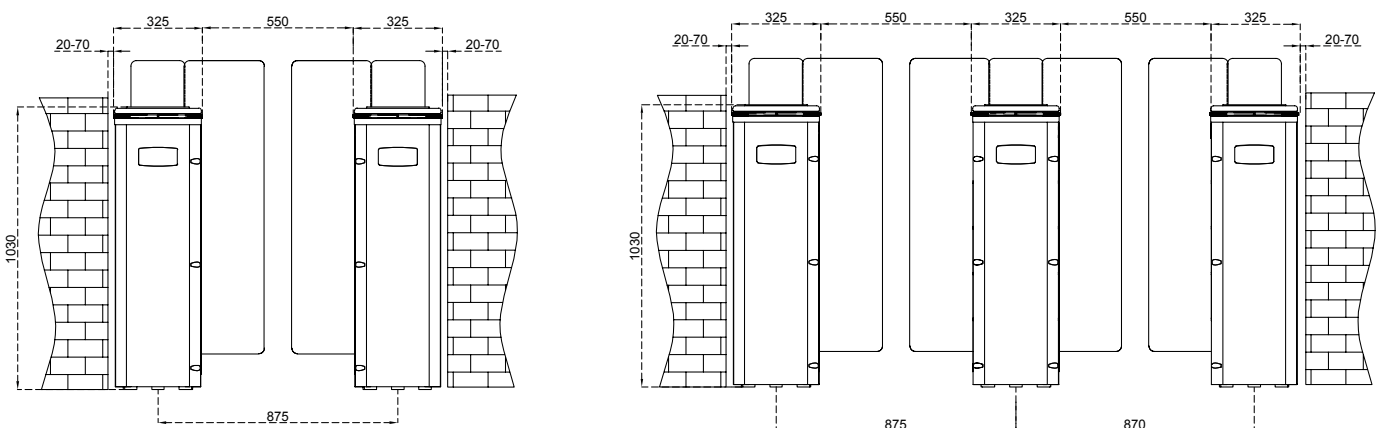

*Design and specifications are subject to change without notice. *All dimensions are in mm.

SG 55 S-S
Glass Wing Height : 900 mm

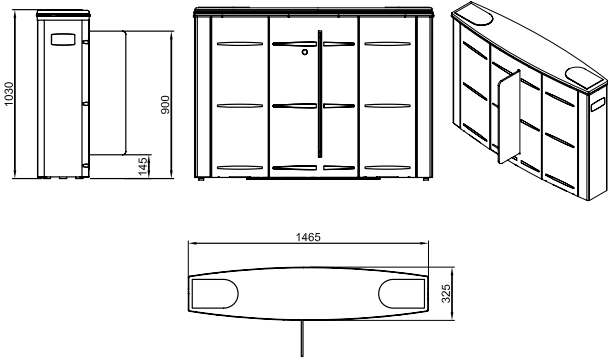

SG 55 S-C
Glass Wing Height : 900 mm

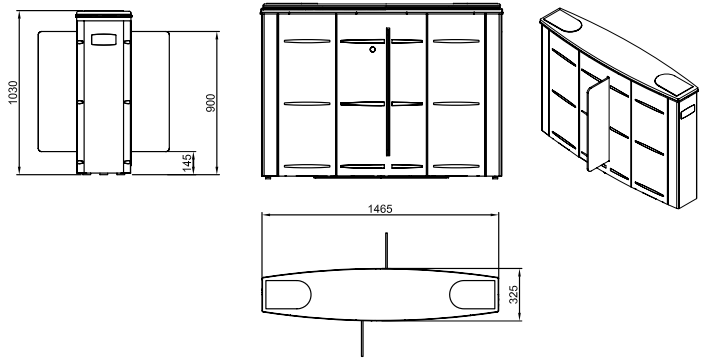

SG 55 M-S
Glass Wing Height : 1200 mm

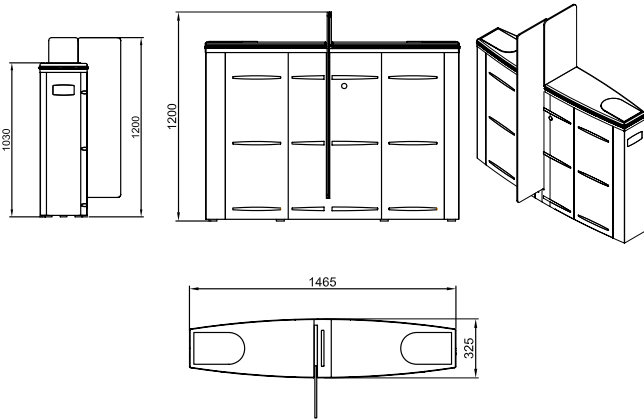

SG 55 M-C
Glass Wing Height : 1200 mm

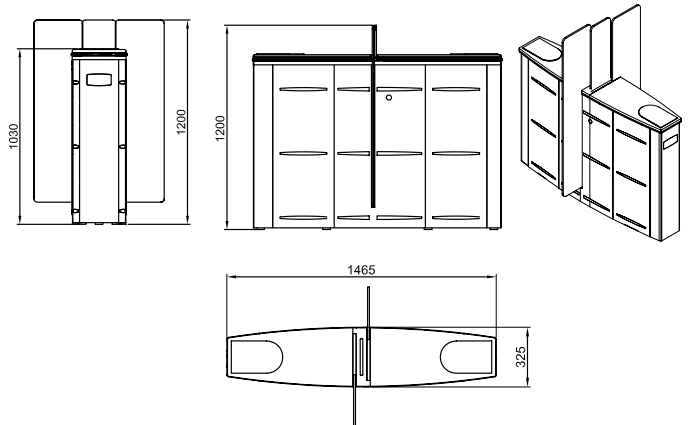

SG 55 T-S
Glass Wing Height : 2000 mm

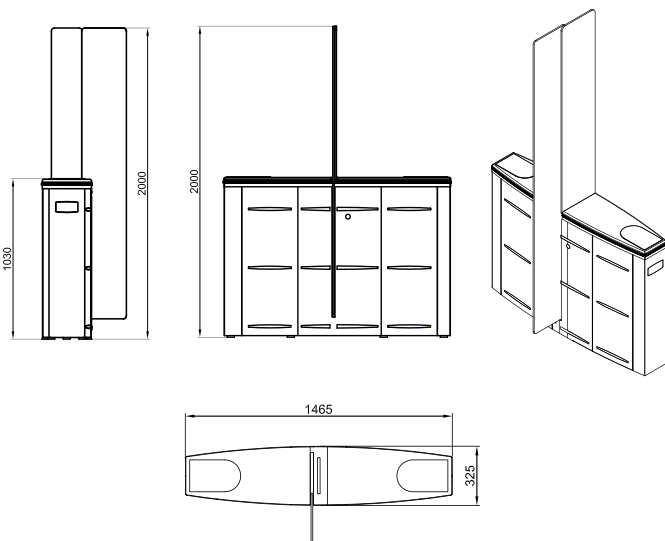

SG 55 T-C
Glass Wing Height : 2000 mm

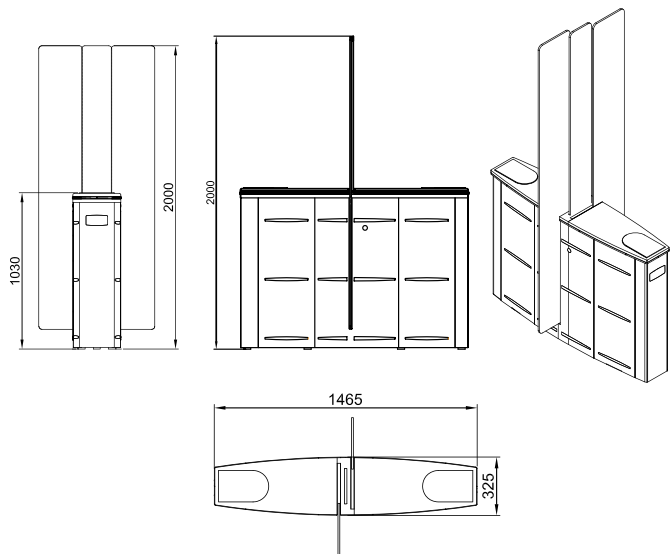

SLIDING GATE 90



- Power Requirements** : 110/220-240 V. 60/50Hz. AC (%±10) 24V.DC
Single Unit: At standby ~10W. during operation ~39W.
Center Unit: At standby ~20W. during operation ~78W.
- Wing Features** : RGB LED illuminated 12mm impact resistant tempered glass (Opt. polycarbon) wings.
- Body Features** : The body is made of 304-grade (Opt. 316-grade) satin finished stainless steel. Natural granite (Star Galaxy Black Pattern) stone on top is standard feature for a decorative and aesthetical appearance. (Opt. materials and patterns available).
- Operation Temperature, Humidity, IP Rating, MCBF** : -20°C to + 68°C / RH 95% non-condensing / IP 44 indoor model / 1M cycles.
- Control System** : All inputs are opto-coupler protected. Compatible with all access control systems that provide dry contact or grounding outputs. Optional RS232/RS485/TCP IP control module is available.
- System Features & Operation** : Electronically controlled rapid wing movement for quick and smooth bi-directional passages. Internal dip switch selectable free passage by photocell detection, restricted access, controlled access on both or single direction modes are built in features.
- Emergency Mode** : System allows free passage in emergency mode and in case of power failure (powered by internal back-up battery).
- Flow Rate** : Wing opening speed/time: 0,5 sec. wing closing speed/time: 0,5 sec.
Nominal: ~30 - 60 passages/minute (recommended reference figure).
*Utilisation of different access control units can change the flow rate.
- Standard Features** : Dot matrix direction and status indicators, natural granite top lid, stainless steel and acrylic reader cover plates for both directions, luggage trolley passage functionality.
- Optional Accessories and Applications** : Tempered glass side (lateral) panels, remote control unit, interface unit for PC, RS485, RS232 and LAN, counter, audio-messaging system, alarm sensor, floor mounting plate, coin slot/intelligent coin system and coin box, separator, card reader pole.
- Note** : A passage lane consists of min. 2 pieces of single units facing each other.

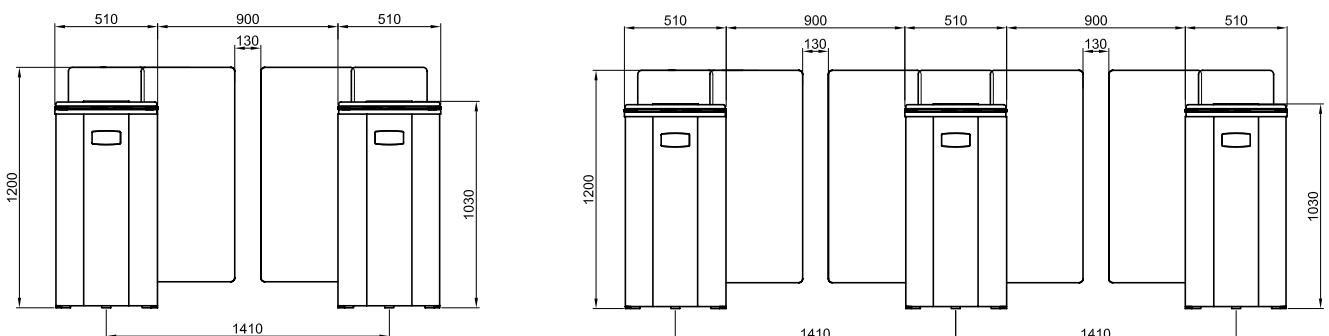

SG 90 S-S
Glass Wing Height : 900 mm

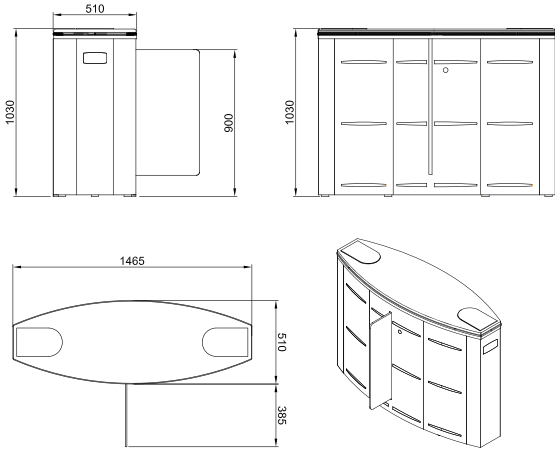

SG 90 S-C
Glass Wing Height : 900 mm

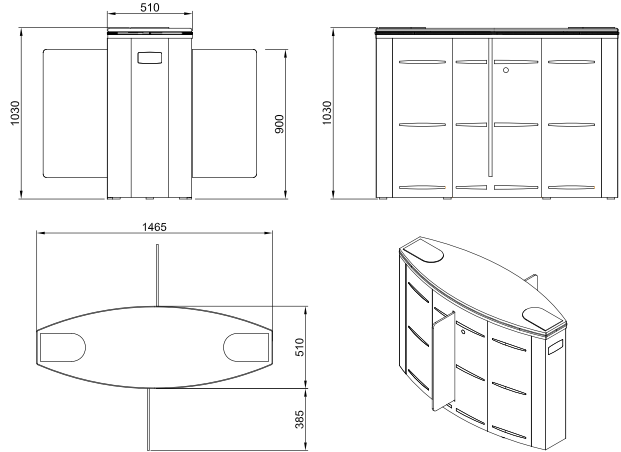

SG 90 M-S
Glass Wing Height : 1200 mm

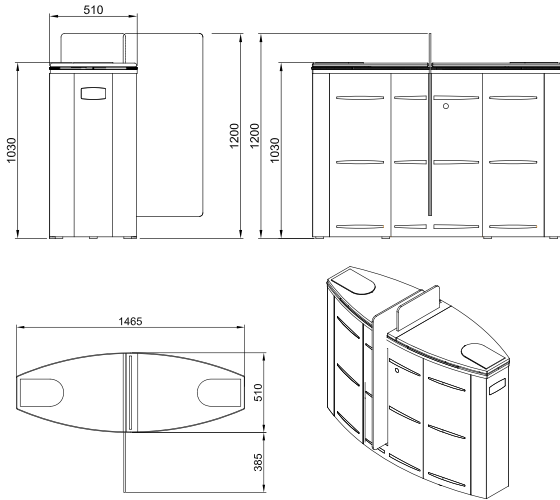

SG 90 M-C
Glass Wing Height : 1200 mm

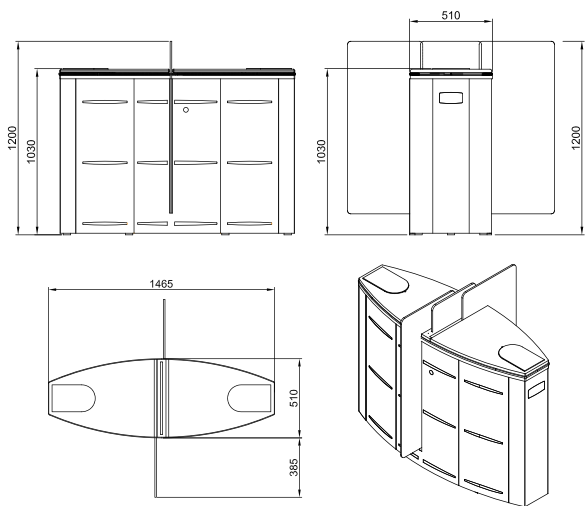

SG 90 T-S
Glass Wing Height : 2000 mm

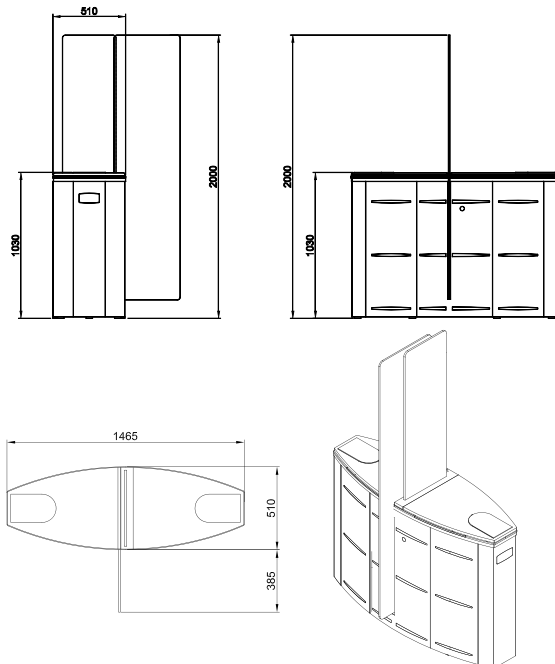

SG 90 T-C
Glass Wing Height : 2000 mm

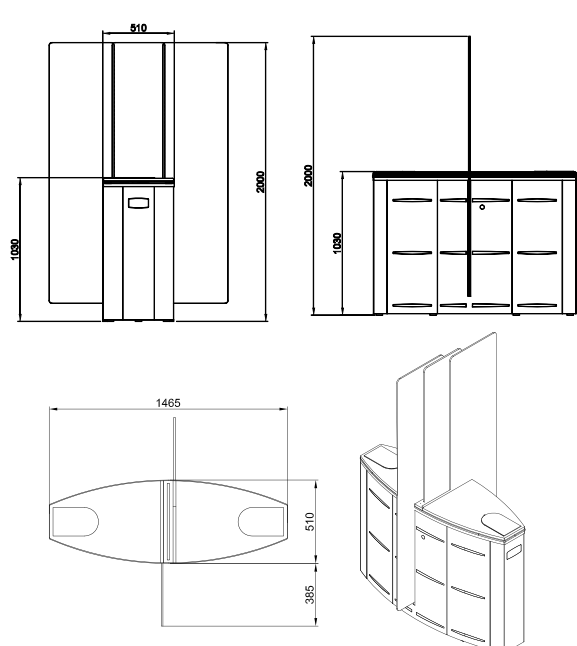



Türk milletinin
karakter ve
adetlerine
en uygun olan
idare;
Cumhuriyet
İdaresidir.
"1924"
Atatürk

EMEK BEDE
KİŞİLER



Glass Line Series



GL A1



- Power Requirements** : 110/220-240 V. 60/50 Hz. AC (%±10) 24 V. DC at standby ~2W. max. ~65W.
- Wing Features** : Impact resistant 10 mm thick tempered glass (Opt. polycarbon or acrylic). Available in 550 mm or 900 mm standard lengths.
- Body Features** : Single piece 304-grade (Opt. 316-grade) satin finished and circular stainless steel body. Standard 20 mm thick natural granite (Star Galaxy Black) stone top lid for a decorative and aesthetical appearance.
- Operation Temperature, Humidity, IP Rating, MCBF** : -20°C to + 68°C (Opt. -50°C with heater unit), RH 95% non-condensing / IP 44 indoor model (for pipe wing versions IP 56 option is available.) / 1M cycles.
- Control System** : All inputs are opto-coupler protected. Compatible with all access control systems that provide dry contact or grounding outputs. Optional RS232/RS485/TCP IP control module is available.
- Operation** : Electronically controlled DC motor driven bi-directional system.
- Emergency Mode** : System allows free passage in emergency mode and in case of power failure.
- Flow Rate** : Wing opening /closing time ~1,5 / - 2,5 sec.
- Standard Features** : Circular RGB LED status indicator.
- Optional Accessories and Applications** : Remote control unit, interface unit for PC, RS485, RS232 and LAN, counter, audio-messaging system, floor mounting plate, separator, card reader pole.
Exit gate functionality to be used on emergency escape routes as per EltVTR 1997-12 and DIN EN 60950-1:2011-01 (GL A1 FWZ).

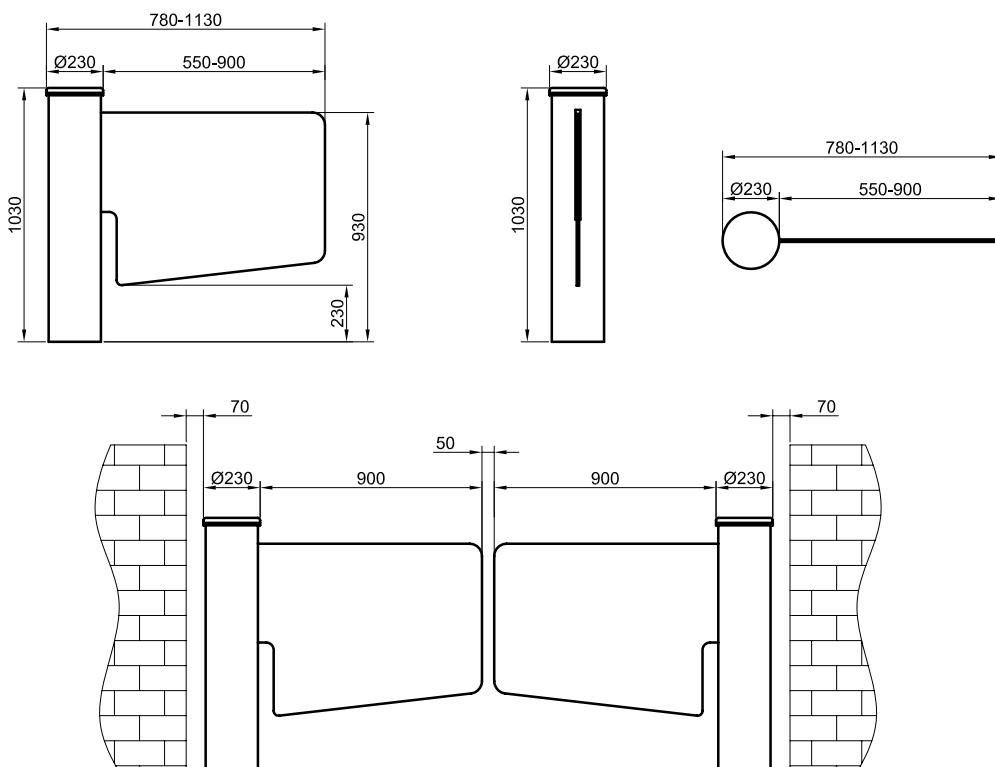

**Design and specifications are subject to change without notice. *All dimensions are in mm.*



GL A3



- Power Requirements** : 110/220-240 V. 60/50 Hz. AC (%±10) 24 V. DC at standby ~2W. max. ~65W.
- Wing Features** : Three impact resistant 10 mm. thick tempered glass wings. (Opt. polycarbon or acrylic).
- Body Features** : Single piece 304-grade (Opt. 316-grade) satin finished stainless steel body. Curved-tempered glass barriers on sides. Natural granite or polished mahogany top lid options. Polished mahogany covering is included on separator railings with mahogany top lid version. Stainless steel separator railings with granite top lid version.
- Operation Temperature, Humidity, IP Rating, MCBF** : -20°C to +68°C (Opt. -50°C with heater unit), RH 95% non-condensing / IP 44 indoor model / 1M cycles.
- Control System** : All inputs are opto-coupler protected. Compatible with all access control systems that provide dry contact or grounding outputs. Optional RS232/RS485/TCP IP control module is available.
- Operation** : Electronically controlled DC motor driven bi-directional system.
- Emergency Mode** : System allows free passage in emergency mode and in case of power failure.
- Flow Rate** : Capacity of mechanism: ~44 passages/minute; nominal: ~13 passages-per-minute (recommended reference figure).
*Utilisation of different access control units can change the flow rate.
- Standard Features** : Circular RGB LED status indicator.
- Optional Accessories and Applications** : Remote control unit, interface unit for PC, RS485, RS232 and LAN, counter, audio-messaging system, floor mounting plate, separator, card reader pole.

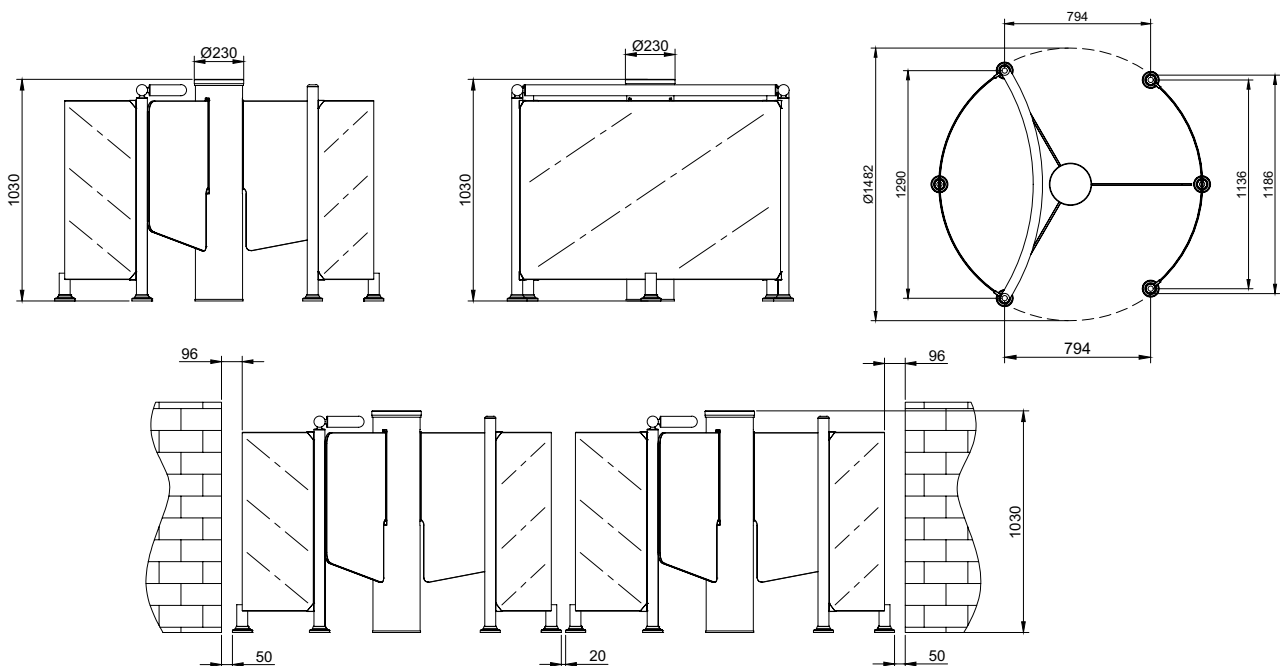

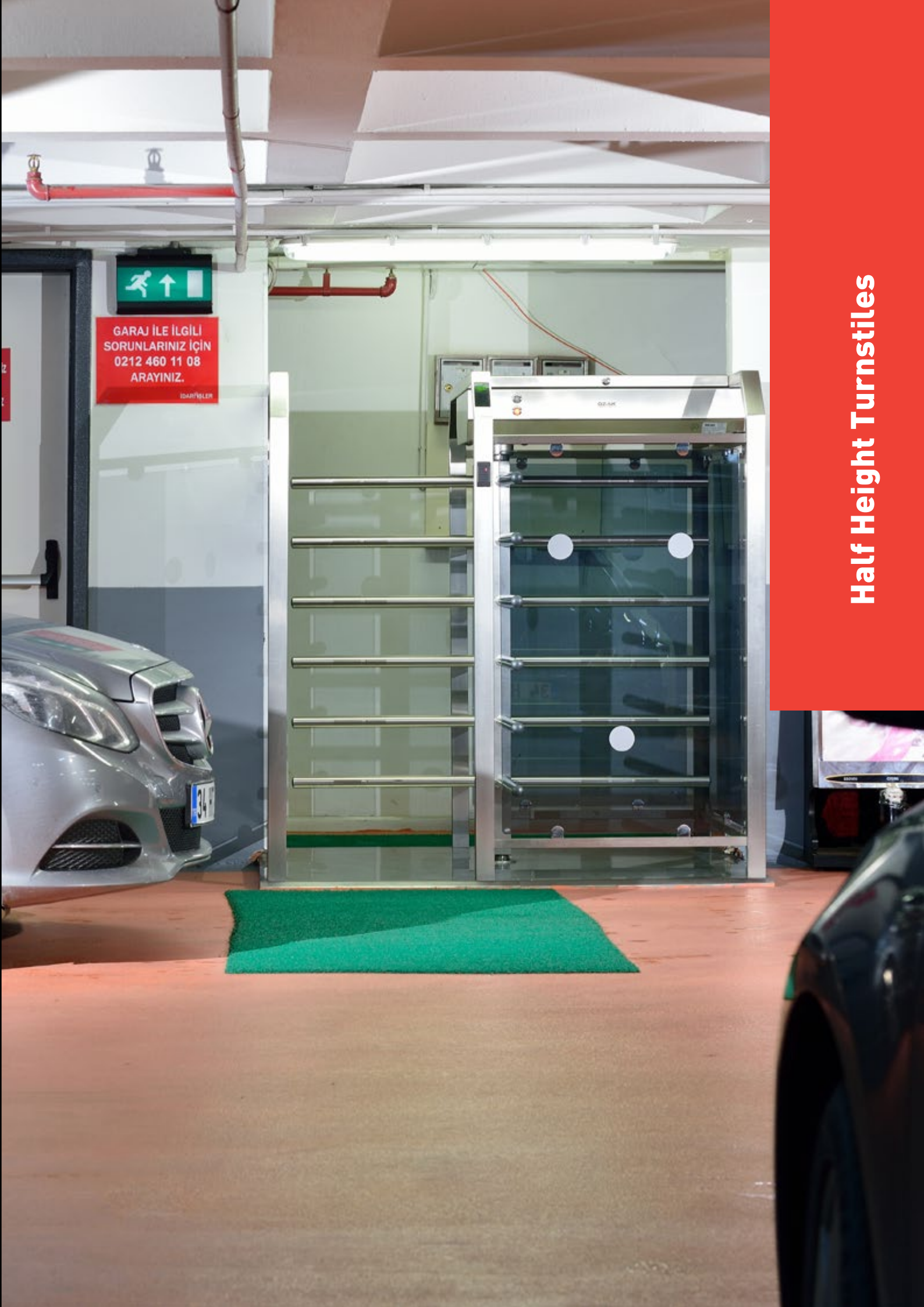

GARAJ İLE İLGİLİ
SORUNLARINIZ İÇİN
0212 460 11 08
ARAYINIZ.
ISARFELER

Half Height Turnstiles



HT 400 S



- Power Requirements** : 110/220-240 V. 60/50Hz. AC (%±10) 24V. DC at standby ~6 W. max. ~16,2W.
- Arm Features** : Four-section rotor (90 degrees) arm. Each section contains five Ø40mmx2mm, 304-grade stainless steel (Opt. Ø42, Ø45 mm) arms.
- Body Features** : 304-grade (Opt. 316-grade) stainless steel with brushed (Opt. satin) surface. Tempered glass or vertical stainless steel bar (depending on choice) front and side separator panels.
- Operation Temperature, Humidity, IP Rating, MCBF** : -20°C to +68°C (Opt. -50°C with heater unit), RH 95% non-condensing / IP 54 outdoor model (Opt. IP 56) / 1M cycles.
- Control System** : All inputs are opto-coupler protected. Compatible with all access control systems that provide dry contact or grounding outputs. Optional RS232/RS485/TCP IP control module is available.
- Operation** : Manually operated bi-directional system (optional motorized) with dip switch selectable operational modes including controlled access on both sides, one side free (exit or entry) and other side controlled access and access restriction modes.
- Emergency Mode** : System allows free passage in emergency mode and in case of power failure (fail safe default). Fail lock option is available.
- Flow Rate** : Capacity of mechanism (manual system): ~ 60 passages/minute;
Nominal: ~18 passages/minute (recommended reference figure).
*Utilisation of different access control units can change the flow rate.
- Standard Features** : Dot matrix LED direction and status indicators.
- Optional Accessories and Applications** : Remote control units, interface unit for PC, RS485, RS232 and LAN, counter, audio-messaging system, floor mounting plate, coin slot/intelligent coin system and coin box, card reader pole, seat limiter for stadium solutions, animated indicators, internal battery and charge unit, motor driven unit, heater positive unit, separators, card reader mounting bracket.

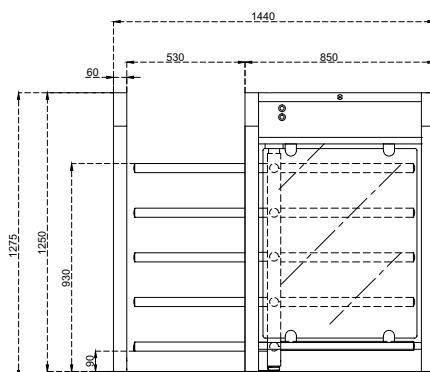
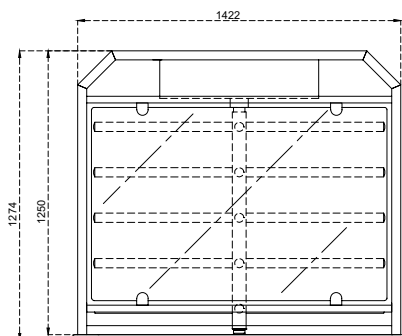
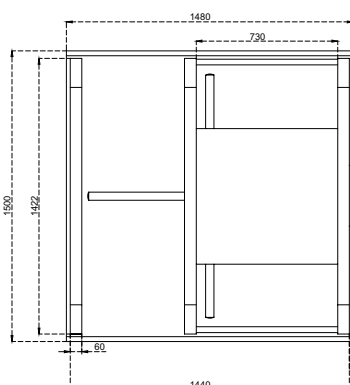

**Design and specifications are subject to change without notice. *All dimensions are in mm.*

HT 400 D

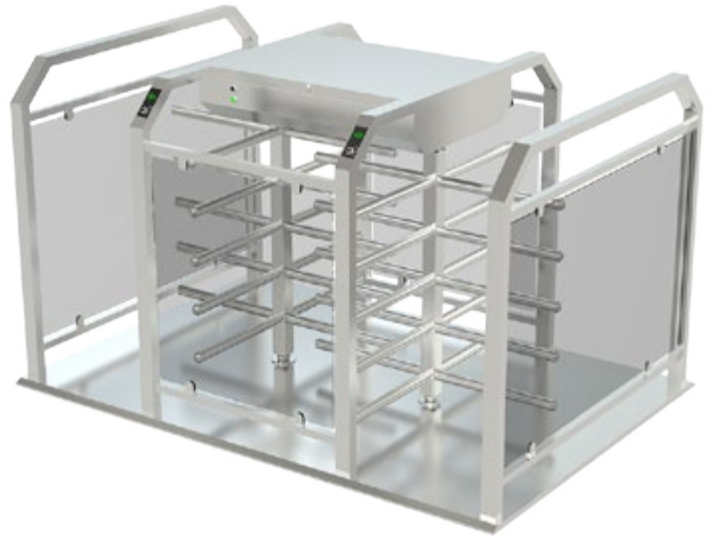

- Power Requirements** : 110/220-240 V. 60/50Hz. AC (%±10) 24V. DC at standby ~6 W. + ~6 W. ; max. ~16,2W. + 16,2W.
- Arm Features** : A pair of four-section (90 degrees) rotors. Each section contains five Ø40mmx2mm, 304-grade stainless steel (Opt. Ø42, Ø45 mm) arms.
- Body Features** : 304-grade (Opt. 316-grade) stainless steel with brushed (Opt. satin) surface. Tempered glass or vertical stainless steel bar (depending on choice) front and side separator panels.
- Operation Temperature, Humidity, IP Rating, MCBF** : -20°C to +68°C (Opt. -50°C with heater unit), RH 95% non-condensing / IP 54 outdoor model (Opt. IP 56) / 1M cycles.
- Control System** : All inputs are opto-coupler protected. Compatible with all access control systems that provide dry contact or grounding outputs. Optional RS232/RS485/TCP IP control module is available.
- Operation** : Manually operated bi-directional system (optional motorized) with dip switch selectable operational modes including controlled access on both sides, one side free (exit or entry) and other side controlled access and access restriction modes.
- Emergency Mode** : System allows free passage in emergency mode and in case of power failure (fail safe default). Fail lock option is available.
- Flow Rate** : Capacity of mechanism (manual system): ~ 60 + ~ 60 passages/minute;
Nominal: ~ 18 + ~ 18 passages/minute (recommended reference figure).
*Utilisation of different access control units can change the flow rate.
- Standard Features** : Dot matrix LED direction and status indicators.
- Optional Accessories and Applications** : Remote control units, interface unit for PC, RS485, RS232 and LAN, counter, audio-messaging system, floor mounting plate, coin slot/intelligent coin system and coin box, card reader pole, seat limiter for stadium solutions, animated indicators, internal battery and charge unit, motor driven unit, heater positive unit, separators, card reader mounting bracket.

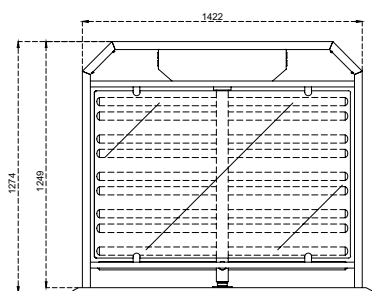
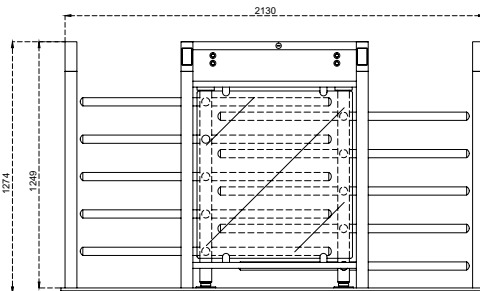
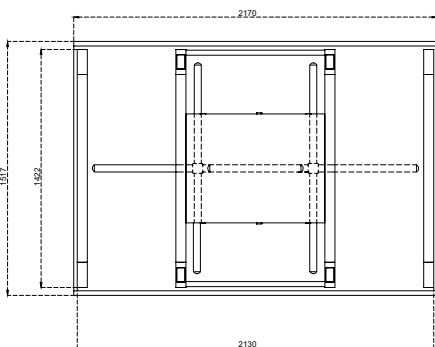

Full Height Turnstiles **3 ARMS (120°)**







BT 312 S



- Power Requirements** : 110/220-240 V. 60/50Hz. AC (%±10) 24V. DC at standby ~6W. max. ~16,2W.
- Arm Features** : Three-section rotor (120 degrees). Each section contains nine Ø42x2.5mm electrostatic powder coated hot dip galvanized or Ø40x2 mm stainless steel (Opt. Ø38, Ø42 and Ø45mm) arms.
- Body Features** : 304-grade (Opt. 316-grade) brushed finished stainless steel, electrostatic painted surface or mixed combination options. (Opt. hot dip galvanizing under coating for outdoor models). Optionally available to comply with UK H&S regulations of max. 98 mm gap between upright profiles.
- Operation Temperature, Humidity, IP Rating, MCBF** : -20°C to +68°C (Opt. -50°C with heater unit), RH 95% non-condensing / IP 54 outdoor model (Opt. IP 56) / 1M cycles.
- Control System** : All inputs are opto-coupler protected. Compatible with all access control systems that provide dry contact or grounding outputs. Optional RS232/RS485/TCP IP control module is available.
- Operation** : Manually operated bi-directional system (optional motorized) with dip switch selectable operational modes including controlled access on both sides, one side free (exit or entry) and other side controlled access and access restriction modes.
- Emergency Mode** : The rotor spins freely to allow free passage (fail safe default). Fail lock option is available.
- Flow Rate** : Capacity of mechanism (manual system): ~ 60 passages/minute; nominal: ~18 passages/minute (recommended reference figure).
*Utilisation of different access control units can change the flow rate.
- Standard Features** : LED direction and status indicators and downlight.
- Optional Accessories and Applications** : Remote control units, interface unit for PC, RS485, RS232 and LAN, counter, audio-messaging system, floor mounting plate, coin slot/intelligent coin system and coin box, card reader pole, seat limiter for stadium solutions, animated indicators, internal battery and charge unit, motor driven unit, heater positive unit, separators, card reader mounting bracket, down light.

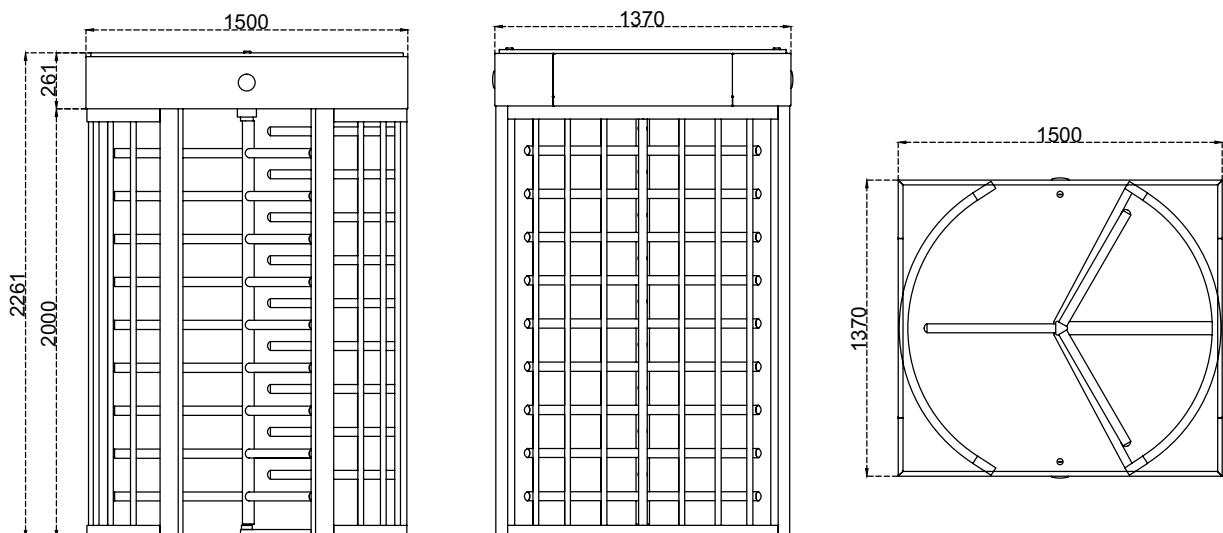

**Design and specifications are subject to change without notice. *All dimensions are in mm.*

BT 312 D



- Power Requirements** : 110/220-240 V. 60/50Hz. AC (%±10) 24V. DC, at standby ~6W. + ~6W. max. ~16,2W. + ~16,2W.
- Arm Features** : A pair of three-section rotors (120 degrees). Each section contains ten Ø42x2.5mm electrostatic powder coated hot dip galvanized or Ø40x2 mm stainless steel (Opt. Ø38, Ø42 and Ø45mm) arms.
- Body Features** : 304-grade (Opt. 316-grade) brushed finished stainless steel, electrostatic painted surface or mixed combination options. (Opt. hot dip galvanizing under coating for outdoor models). Optionally available to comply with UK H&S regulations of max. 98 mm gap between upright profiles.
- Operation Temperature, Humidity, IP Rating, MCBF** : -20°C to + 68°C (Opt. -50°C with heater unit), RH 95% non-condensing / IP 54 outdoor model (Opt. IP 56) / 1M cycles.
- Control System** : All inputs are opto-coupler protected. Compatible with all access control systems that provide dry contact or grounding outputs. Optional RS232/RS485/TCP IP control module is available.
- Operation** : Manually operated bi-directional system (optional motorized) with dip switch selectable operational modes including controlled access on both sides, one side free (exit or entry) and other side controlled access and access restriction modes.
- Emergency Mode** : The rotor spins freely to allow free passage (fail safe default). Fail lock option is available.
- Flow Rate** : Capacity of mechanism (manual system): ~60 + ~60 passages/minute;
Nominal: ~18 + ~18 passages/minute (recommended reference figure).
*Utilisation of different access control units can change the flow rate.
- Standard Features** : LED direction and status indicators and downlight.
- Optional Accessories and Applications** : Remote control units, interface unit for PC, RS485, RS232 and LAN, counter, audio-messaging system, floor mounting plate, coin slot/intelligent coin system and coin box, card reader pole, seat limiter for stadium solutions, animated indicators, internal battery and charge unit, motor driven unit, heater positive unit, separators, card reader mounting bracket, down light.

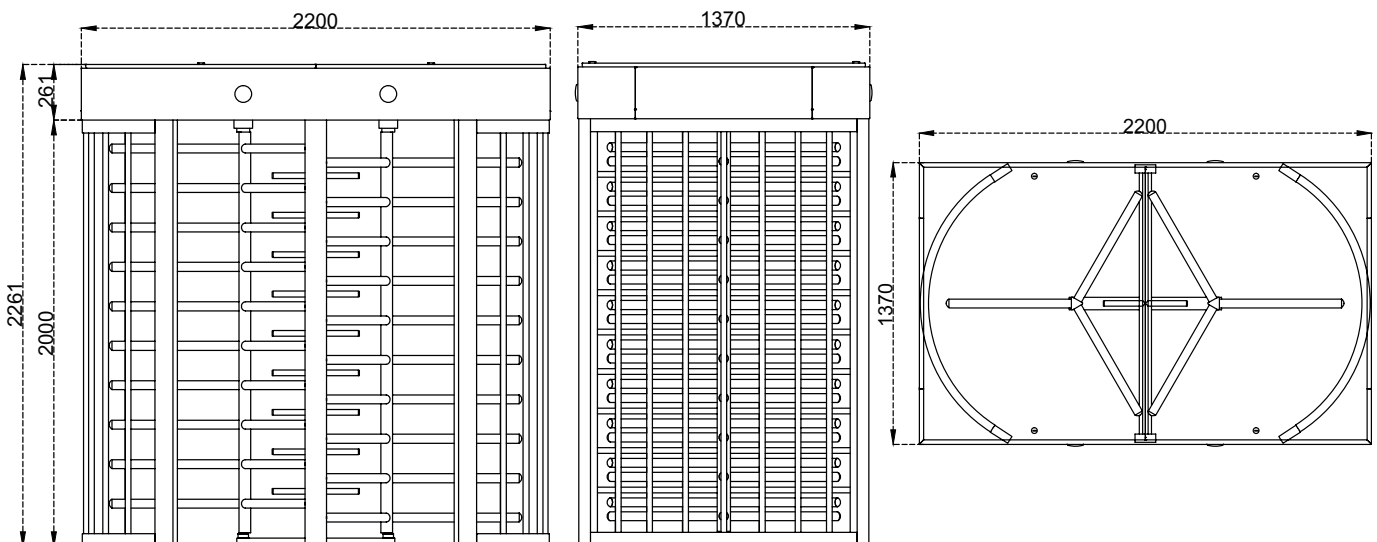

**Design and specifications are subject to change without notice. *All dimensions are in mm.*

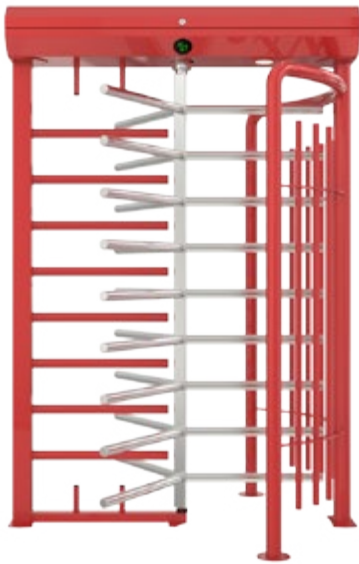

BTX 300 S



- Power Requirements** : 110/220-240 V. 60/50Hz. AC (%±10) 24V. DC at standby ~6,8W. max. ~17W.
- Arm Features** : Three-section rotor (120 degrees). Each section contains nine Ø42x2.5mm electrostatic powder coated hot dip galvanized or Ø40x2 mm stainless steel (Opt. Ø38, Ø42 and Ø45mm) arms.
- Body Features** : 304-grade (Opt. 316-grade) brushed finished stainless steel, electrostatic painted surface or mixed combination versions. (Opt. hot dip galvanizing under coating for outdoor models). Complying to UK H&S regulations of max. 98 mm gap between upright profiles.
- Operation Temperature, Humidity, IP Rating, MCBF** : -20°C to +68°C (Opt. -50°C with heater unit), RH 95% non-condensing / IP 54 outdoor model (Opt. IP 56) / 1M cycles.
- Control System** : All inputs are opto-coupler protected. Compatible with all access control systems that provide dry contact or grounding outputs. Optional RS232/RS485/TCP IP control module is available.
- Operation** : Manually operated bi-directional system (optional motorized) with dip switch selectable operational modes including controlled access on both sides, one side free (exit or entry) and other side controlled access and access restriction modes.
- Emergency Mode** : System allows free passage in emergency mode and in case of power failure (fail safe default). Fail lock option is available.
- Flow Rate** : Capacity of mechanism (manual system): ~ 60 passages/minute; Nominal: ~18 passages/minute (recommended reference figure).
*Utilisation of different access control units can change the flow rate.
- Standard Features** : LED direction, status indicators and downlight.
- Optional Accessories and Applications** : Remote control units, interface unit for PC, RS485, RS232 and LAN, counter, audio-messaging system, floor mounting plate, coin slot/intelligent coin system and coin box, card reader pole, seat limiter for stadium solutions, animated indicators, internal battery and charge unit, motor driven unit, heater positive unit, separators, canopy, card reader mounting bracket.

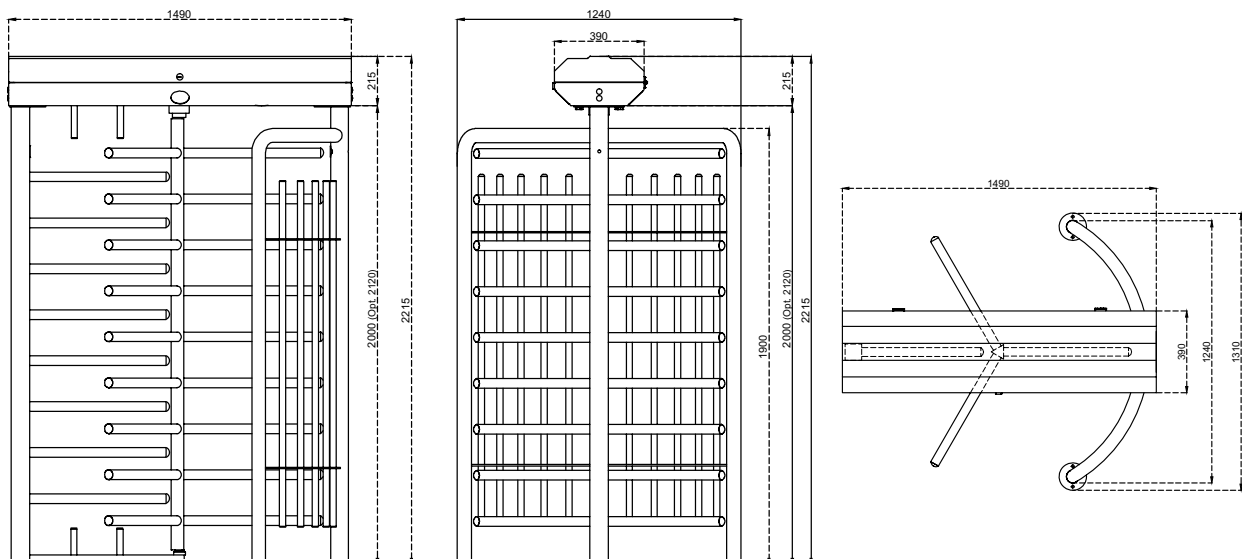

*Design and specifications are subject to change without notice. *All dimensions are in mm.

BTX 300 D



- Power Requirements** : 110/220-240 V. 60/50Hz. AC (%±10) 24V. DC at standby ~6,8W + 6,8W. max. ~17W + 17W
- Arm Features** : A pair of three-section rotor (120 degrees). Each section contains nine Ø42x2.5mm electrostatic powder coated hot dip galvanized or Ø40x2 mm stainless steel (Opt. Ø38, Ø42 and Ø45mm) arms.
- Body Features** : 304-grade (Opt. 316-grade) brushed finished stainless steel, electrostatic painted surface or mixed combination versions. (Opt. hot dip galvanizing under coating for outdoor models). Complying to UK H&S regulations of max. 98 mm gap between upright profiles.
- Operation Temperature, Humidity, IP Rating, MCBF** : -20°C to +68°C (Opt. -50°C with heater unit), RH 95% non-condensing / IP 54 outdoor model (Opt. IP 56) / 1M cycles.
- Control System** : All inputs are opto-coupler protected. Compatible with all access control systems that provide dry contact or grounding outputs. Optional RS232/RS485/TCP IP control module is available.
- Operation** : Manually operated bi-directional system (optional motorized) with dip switch selectable operational modes including controlled access on both sides, one side free (exit or entry) and other side controlled access and access restriction modes.
- Emergency Mode** : System allows free passage in emergency mode and in case of power failure (fail safe default). Fail lock option is available.
- Flow Rate** : Capacity of mechanism (manual system): ~60 + ~60 passages/minute; nominal: ~18 + ~18 passages/minute (recommended reference figure).
*Utilisation of different access control units can change the flow rate.
- Standard Features** : LED direction, status indicators and downlight.
- Optional Accessories and Applications** : Remote control units, interface unit for PC, RS485, RS232 and LAN, counter, audio-messaging system, floor mounting plate, coin slot/intelligent coin system and coin box, card reader pole, seat limiter for stadium solutions, animated indicators, internal battery and charge unit, motor driven unit, heater positive unit, separators, canopy, card reader mounting bracket.

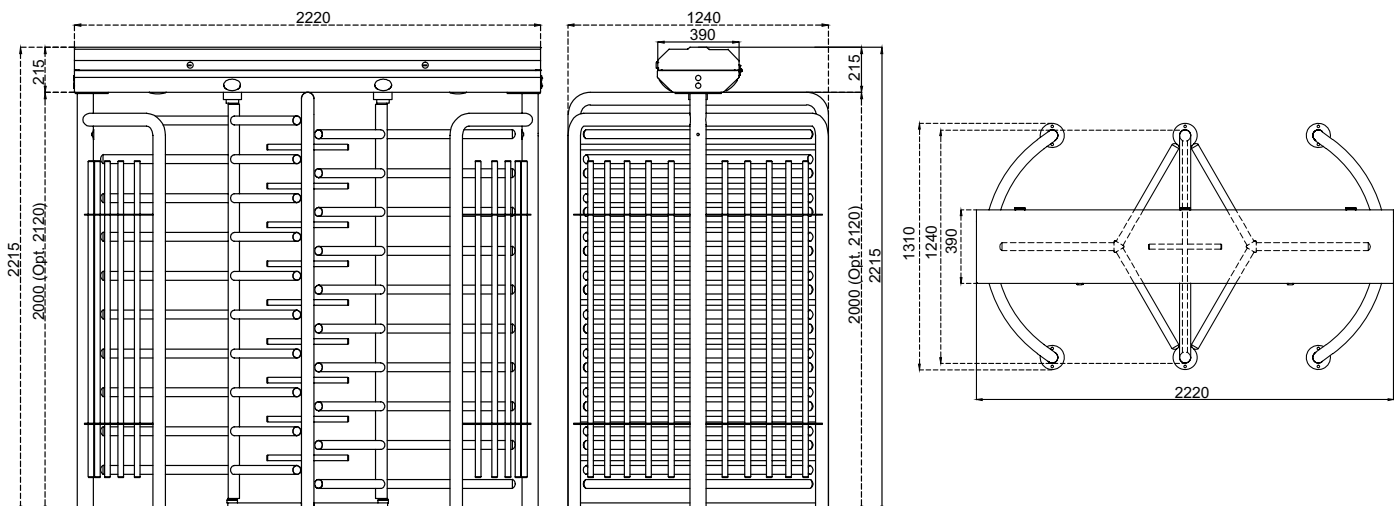

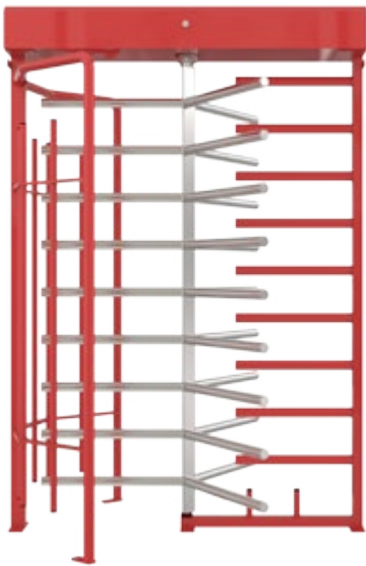

ECOLINE 300 S



- Power Requirements** : 110/220-240 V. 60/50Hz. AC (%±10) 24V. DC at standby ~4,5W. max. ~13,5W.
- Arm Features** : Three-section rotor (120 degrees). Each section contains nine Ø42x2.5mm electrostatic powder coated hot dip galvanized or Ø40x2 mm stainless steel (Opt. Ø38, Ø42 and Ø45mm) arms.
- Body Features** : 304-grade (Opt. 316-grade) brushed finished stainless steel, electrostatic painted surface or mixed combination versions. (Opt. hot dip galvanizing under coating for outdoor models).
- Operation Temperature, Humidity, IP Rating, MCBF** : -20°C to +68°C (Opt. -50°C with heater unit), RH 95% non-condensing / IP 54 outdoor model (Opt. IP 56) / 1M cycles
- Control System** : All inputs are opto-coupler protected. Compatible with all access control systems that provide dry contact or grounding outputs. Optional RS232/RS485/TCP IP control module is available.
- Operation** : Manually operated bi-directional system (optional motorized) with dip switch selectable operational modes including controlled access on both sides, one side free (exit or entry) and other side controlled access and access restriction modes.
- Emergency Mode** : System allows free passage in emergency mode and in case of power failure (fail safe default). Fail lock option is available.
- Flow Rate** : Capacity of mechanism (manual system): ~ 60 passages/minute;
Nominal: ~ 18 passages/minute (recommended reference figure).
*Utilisation of different access control units can change the flow rate.
- Optional Accessories and Applications** : LED direction and status indicators, remote control units, interface unit for PC, RS485, RS232 and LAN, counter, audio-messaging system, floor mounting plate, coin slot/intelligent coin system and coin box, card reader pole, seat limiter for stadium solutions, animated indicators, internal battery and charge unit, motor driven unit, heater positive unit, separators, card reader mounting bracket, down light.

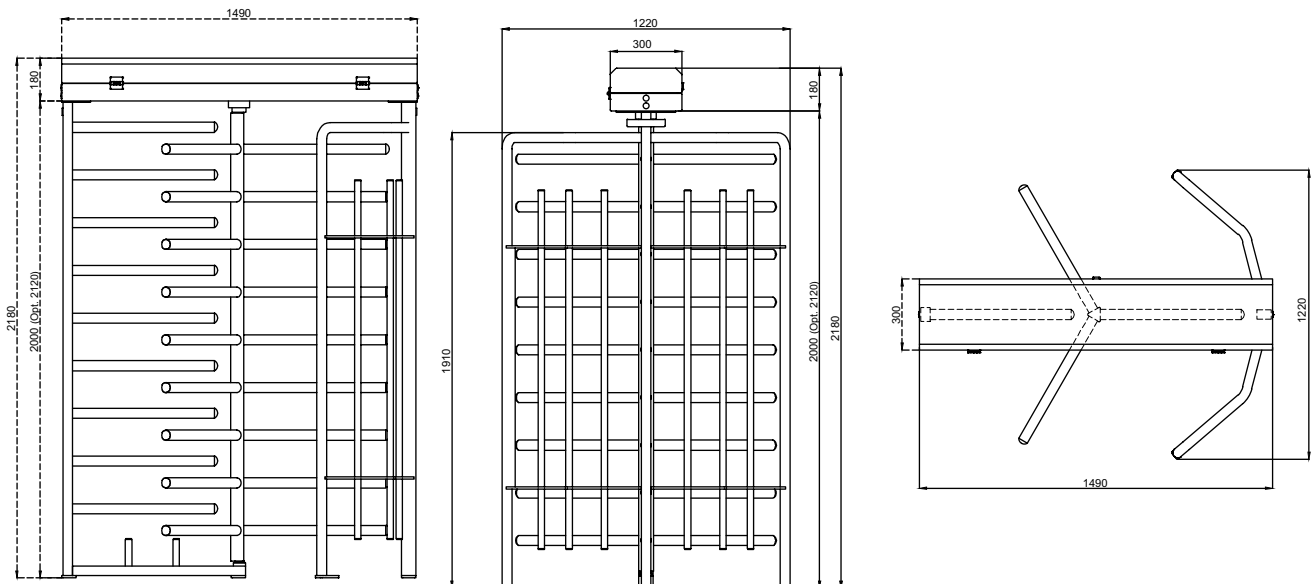

**Design and specifications are subject to change without notice. *All dimensions are in mm.*

ECOLINE 300 D



- Power Requirements** : 110/220-240 V. 60/50Hz. AC (%±10) 24V. DC at standby ~4,5W + 4,5W. max. ~13,5W + 13,5W.
- Arm Features** : A pair of three-section rotor (120 degrees). Each section contains nine Ø42x2.5mm electrostatic powder coated hot dip galvanized or Ø40x2 mm stainless steel (Opt. Ø38, Ø42 and Ø45mm) arms.
- Body Features** : 304-grade (Opt. 316-grade) brushed finished stainless steel, electrostatic painted surface or mixed combination versions. (Opt. hot dip galvanizing under coating for outdoor models).
- Operation Temperature, Humidity, IP Rating, MCBF** : -20°C to +68°C (Opt. -50°C with heater unit), RH 95% non-condensing / IP 54 outdoor model (Opt. IP 56) / 1M cycles.
- Control System** : All inputs are opto-coupler protected. Compatible with all access control systems that provide dry contact or grounding outputs. Optional RS232/RS485/TCP IP control module is available.
- Operation** : Manually operated bi-directional system (optional motorized) with dip switch selectable operational modes including controlled access on both sides, one side free (exit or entry) and other side controlled access and access restriction modes.
- Emergency Mode** : System allows free passage in emergency mode and in case of power failure (fail safe default). Fail lock option is available.
- Flow Rate** : Capacity of mechanism (manual system): ~60 + ~60 passages/minute; nominal: ~18 + ~18 passages/minute (recommended reference figure).
*Utilisation of different access control units can change the flow rate.
- Optional Accessories and Applications** : LED direction and status indicators, remote control units, interface unit for PC, RS485, RS232 and LAN, counter, audio-messaging system, floor mounting plate, coin slot/intelligent coin system and coin box, card reader pole, seat limiter for stadium solutions, animated indicators, internal battery and charge unit, motor driven unit, heater positive unit, separators, card reader mounting bracket, down light.

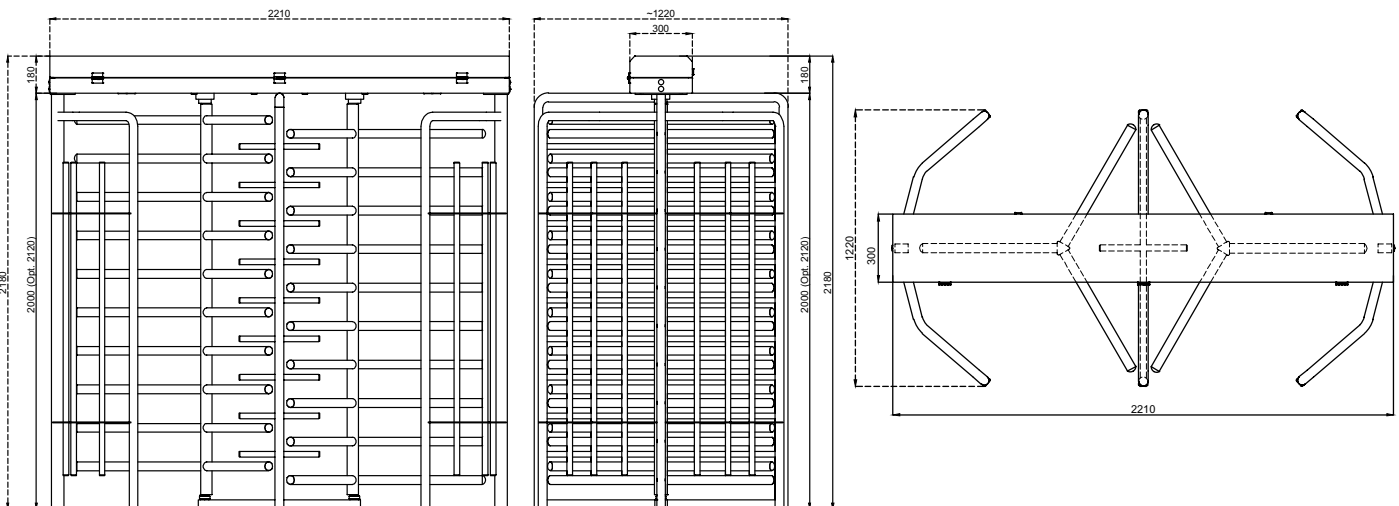

*Design and specifications are subject to change without notice. *All dimensions are in mm.

Full Height Turnstiles - 4 ARMS (90°)



B3



B3





B3



B3





BT 402 S



- Power Requirements** : 110/220-240 V. 60/50Hz. AC (%±10) 24V. DC at standby ~6W. max. ~16,2W.
- Arms Features** : Four-section rotor (90 degrees). Each section contains nine Ø42mmx2.5mm electrostatic powder coated hot dip galvanized or Ø40mm stainless steel (Opt. Ø38, Ø42 and Ø45mm) arms.
- Body Features** : 304-grade (Opt. 316-Grade) brushed finished stainless steel, electrostatic painted surface or mixed combination options. (Opt. Hot dip galvanizing under coating for outdoor models). Optionally available to comply with UK H&S regulations of max. 98 mm gap between upright profiles.
- Operation Temperature, Humidity, IP Rating, MCBF** : -20°C to +68°C (Opt. -50°C with heater unit), RH 95% non-condensing / IP 54 outdoor model (Opt. IP 56) / 1M cycles.
- Control System** : All inputs are opto-coupler protected. Compatible with all access control systems that provide dry contact or grounding outputs. Optional RS232/RS485/TCP IP control module is available.
- Operation** : Manually operated bi-directional system (optional motorized) with dip switch selectable operational modes including controlled access on both sides, one side free (exit or entry) and other side controlled access and access restriction modes.
- Emergency Mode** : System allows free passage in emergency mode and in case of power failure (fail safe default). Fail lock option is available.
- Flow Rate** : Capacity of mechanism (manual system): ~ 60 passages/minute; nominal: ~18 passages/minute (Recommended reference figure).
*Utilisation of different access control units can change the flow rate.
- Standard Features** : LED direction, status indicators and downlight.
- Optional Accessories and Applications** : Remote control units, interface unit for PC, RS485, RS232 and LAN, counter, audio-messaging system, floor mounting plate, coin slot/intelligent coin system and coin box, card reader pole, seat limiter for stadium solutions, animated indicators, internal battery and charge unit, motor driven unit, heater positive unit, separators, canopy, card reader mounting bracket.

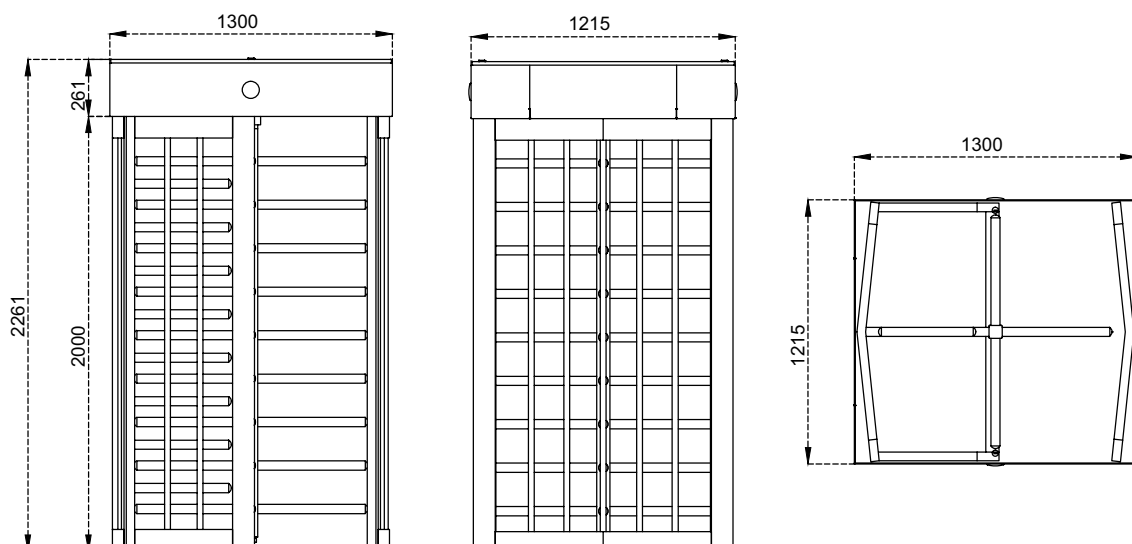

**Design and specifications are subject to change without notice. *All dimensions are in mm.*

BT 402 D

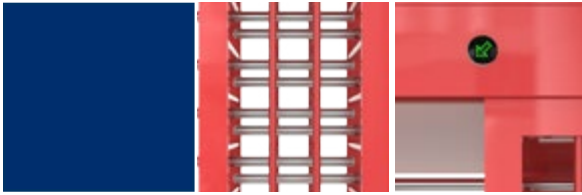

- Power Requirements** : 110/220-240V. 60/50Hz. AC (%±10) 24V. DC, at standby ~6W. + ~6W. max. ~16,2W. + ~16,2W.
- Arms Features** : A pair of four-section (90 degrees) rotors. Each section contains ten Ø42mmx2.5mm electrostatic powder coated hot dip galvanized or Ø40mm stainless steel (Opt. Ø38, Ø42 and Ø45mm) arms.
- Body Features** : 304-grade (Opt. 316-grade) brushed finished stainless steel, electrostatic painted surface or mixed combination options. (Opt. hot dip galvanizing under coating for outdoor models). Optionally available to comply with UK H&S regulations of max. 98 mm gap between upright profiles.
- Operation Temperature, Humidity, IP Rating, MCBF** : -20°C to +68°C (Opt. -50°C with heater unit), RH 95% non-condensing / IP 54 outdoor model (Opt. IP 56) / 1M cycles
- Control System** : All inputs are opto-coupler protected. Compatible with all access control systems that provide dry contact or grounding outputs. Optional RS232/RS485/TCP IP control module is available.
- Operation** : Manually operated bi-directional system (optional motorized) with dip switch selectable operational modes including controlled access on both sides, one side free (exit or entry) and other side controlled access and access restriction modes.
- Emergency Mode** : System allows free passage in emergency mode and in case of power failure (fail safe default). Fail lock option is available.
- Flow Rate** : Capacity of mechanism (manual system): ~60 + ~60 passages/minute;
Nominal: ~18 + ~18 passages/minute (Recommended reference figure).
*Utilisation of different access control units can change the flow rate.
- Standard Features** : LED direction, status indicators and downlight.
- Optional Accessories and Applications** : Remote control units, interface unit for PC, RS485, RS232 and LAN, counter, audio-messaging system, floor mounting plate, coin slot/intelligent coin system and coin box, card reader pole, seat limiter for stadium solutions, animated indicators, internal battery and charge unit, motor driven unit, heater positive unit, separators, canopy, card reader mounting bracket.

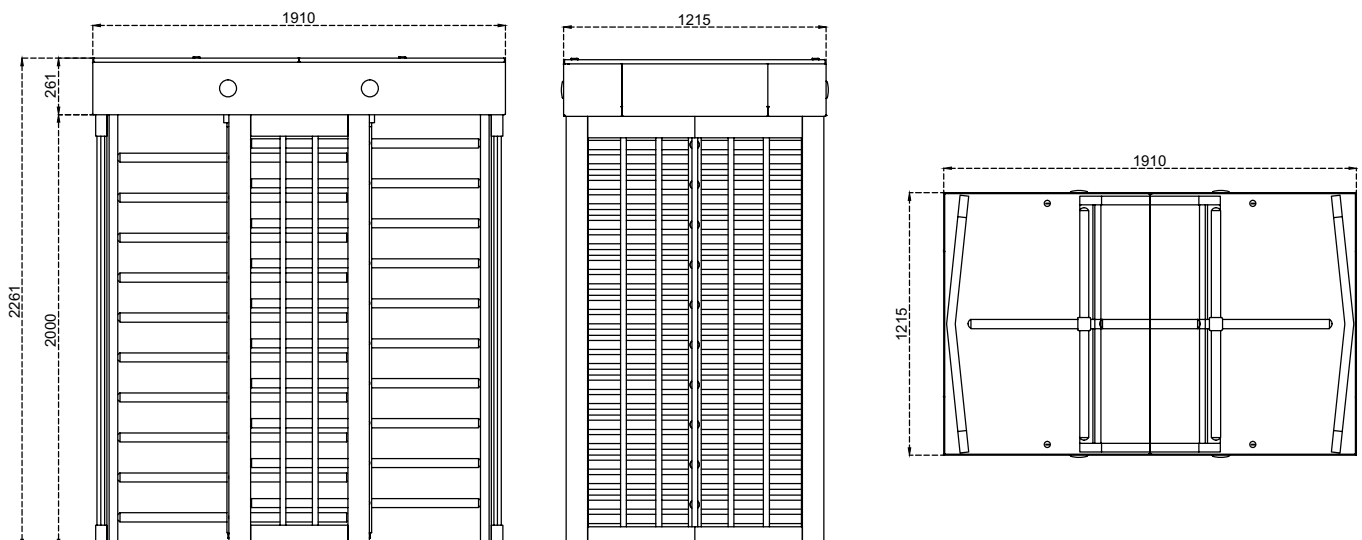

*Design and specifications are subject to change without notice. *All dimensions are in mm.





D6  D6
411 412





BTX 400 S



- Power Requirements** : 110/220-240 V. 60/50Hz. AC (%±10) 24V. DC at standby ~6,8W. max. ~17W.
- Arms Features** : Four-section rotor (90 degrees). Each section contains nine Ø42mmx2.5mm electrostatic powder coated hot dip galvanized or Ø40mm stainless steel (Opt. Ø38, Ø42 and Ø45mm) arms.
- Body Features** : 304-grade (Opt. 316-grade) brushed finished stainless steel, electrostatic painted surface or mixed combination versions. (Opt. hot dip galvanizing under coating for outdoor models). Complying to UK H&S regulations of max. 98 mm gap between upright profiles.
- Operation Temperature, Humidity, IP Rating, MCBF** : -20°C to + 68°C (Opt. -50°C with heater unit), RH 95% non-condensing / IP 54 outdoor model (Opt. IP 56) / 1M cycles
- Control System** : All inputs are opto-coupler protected. Compatible with all access control systems that provide dry contact or grounding outputs. Optional RS232/RS485/TCP IP control module is available.
- Operation** : Manually operated bi-directional system (optional motorized) with dip switch selectable operational modes including controlled access on both sides, one side free (exit or entry) and other side controlled access and access restriction modes.
- Emergency Mode** : System allows free passage in emergency mode and in case of power failure (fail safe default). Fail lock option is available.
- Flow Rate** : Capacity of mechanism (manual system): ~ 60 passages/minute; nominal: ~18 passages/minute (recommended reference figure).
*Utilisation of different access control units can change the flow rate.
- Standard Features** : LED direction and status indicators and downlight.
- Optional Accessories and Applications** : Remote control units, interface unit for PC, RS485, RS232 and LAN, counter, audio-messaging system, floor mounting plate, coin slot/intelligent coin system and coin box, card reader pole, seat limiter for stadium solutions, animated indicators, internal battery and charge unit, motor driven unit, heater positive unit, separators, canopy, card reader mounting bracket.

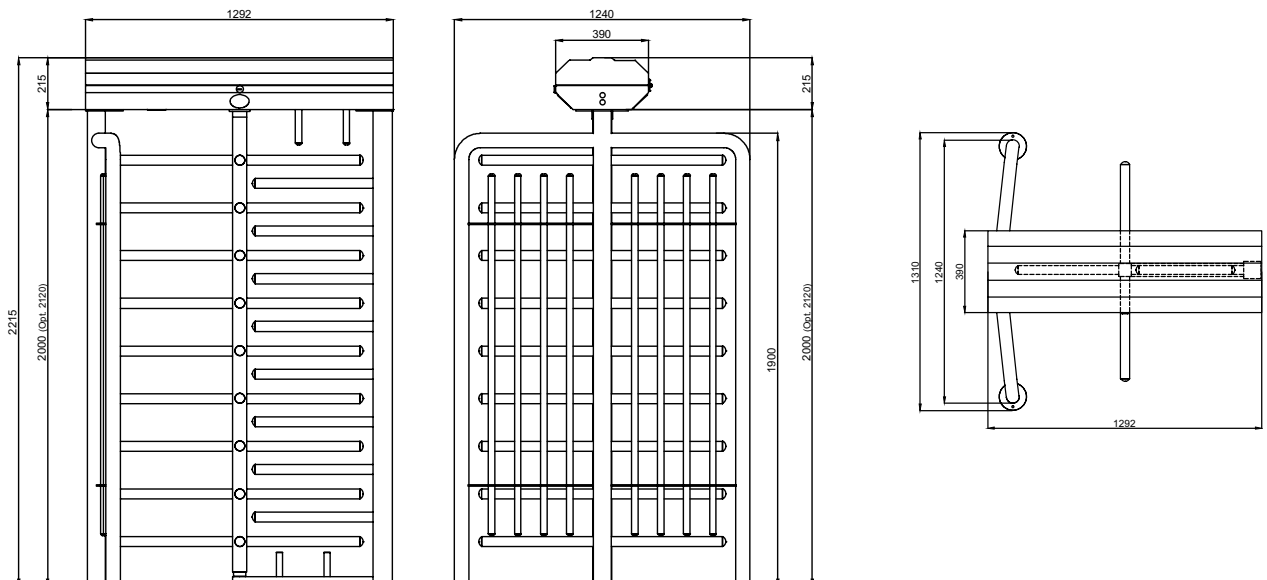

**Design and specifications are subject to change without notice. *All dimensions are in mm.*

BTX 400 D



- Power Requirements** : 110/220-240 V. 60/50Hz. AC (%±10) 24V. DC, at standby ~6,8W. + ~6,8W. max. ~17W. + ~17W.
- Arms Features** : A pair of four-section (90 degrees) rotors. Each section contains ten Ø42mmx2.5mm electrostatic powder coated hot dip galvanized or Ø40mm stainless steel (Opt. Ø38, Ø42 and Ø45mm) arms.
- Body Features** : 304-grade (Opt. 316-grade) brushed finished stainless steel, electrostatic painted surface or mixed combination versions. (Opt. hot dip galvanizing under coating for outdoor models). Opt. Complying to UK H&S regulations of max. 98 mm gap between upright profiles version is available.
- Operation Temperature, Humidity, IP Rating, MCBF** : -20°C to + 68°C (Opt. -50°C with heater unit), RH 95% non-condensing / IP 54 outdoor model (Opt. IP 56) / 1M cycles
- Control System** : All inputs are opto-coupler protected. Compatible with all access control systems that provide dry contact or grounding outputs. Optional RS232/RS485/TCP IP control module is available.
- Operation** : Manually operated bi-directional system (optional motorized) with dip switch selectable operational modes including controlled access on both sides, one side free (exit or entry) and other side controlled access and access restriction modes.
- Emergency Mode** : System allows free passage in emergency mode and in case of power failure (fail safe default). Fail lock option is available.
- Flow Rate** : Capacity of mechanism (manual system): ~60 + ~60 passages/minute;
nominal: ~18 + ~18 passages/minute (recommended reference figure).
*Utilisation of different access control units can change the flow rate.
- Standard Features** : LED direction, status indicators and down light.
- Optional Accessories and Applications** : Remote control units, interface unit for PC, RS485, RS232 and LAN, counter, audio-messaging system, floor mounting plate, coin slot/intelligent coin system and coin box, card reader pole, seat limiter for stadium solutions, animated indicators, internal battery and charge unit, motor driven unit, heater positive unit, separators, canopy, card reader mounting bracket.

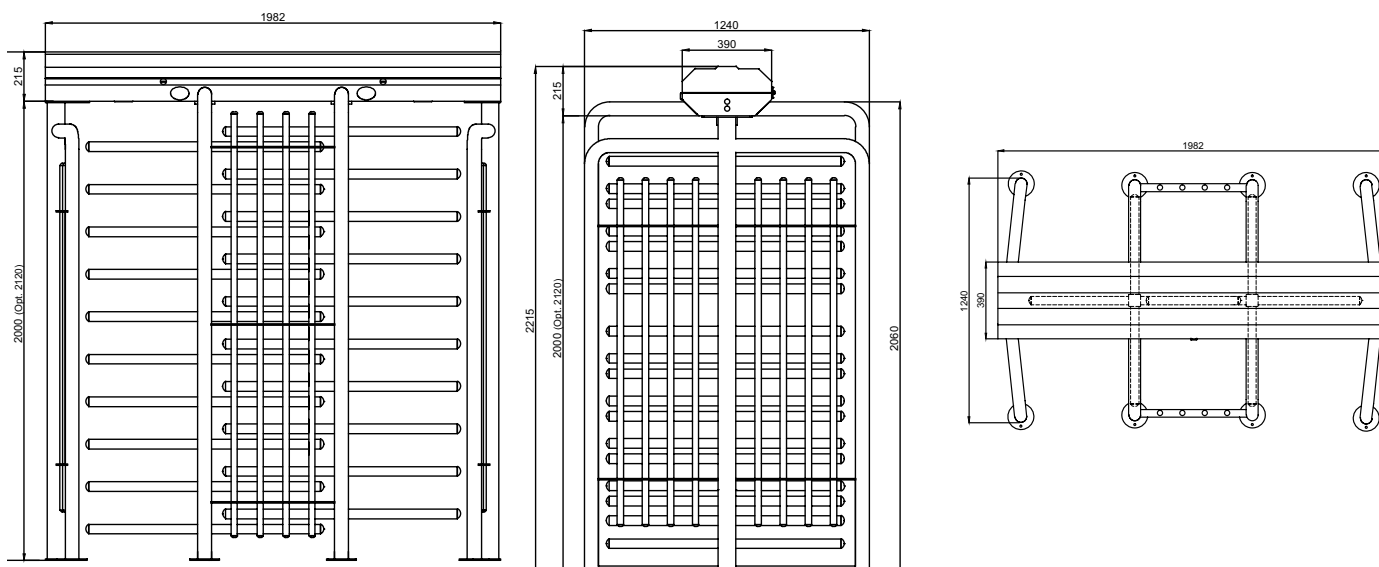

*Design and specifications are subject to change without notice. *All dimensions are in mm.



ECOLINE 400 S



- Power Requirements** : 110/220-240 V. 60/50Hz. AC (%±10) 24V. DC at standby ~4,5W. max. ~13,5W.
- Arms Features** : Four-section rotor (90 degrees). Each section contains nine Ø42mmx2.5mm electrostatic powder coated hot dip galvanized or Ø40mm stainless steel (Opt. Ø38, Ø42 and Ø45mm) arms.
- Body Features** : 304-grade (Opt. 316-grade) brushed finished stainless steel, electrostatic painted surface or mixed combination versions. (Opt. hot dip galvanizing under coating for outdoor models).
- Operation Temperature, Humidity, IP Rating, MCBF** : -20°C to + 68°C (Opt. -50°C with heater unit), RH 95% non-condensing / IP 54 outdoor model (Opt. IP 56) / 1M cycles
- Control System** : All inputs are opto-coupler protected. Compatible with all access control systems that provide dry contact or grounding outputs. Optional RS232/RS485/TCP IP control module is available.
- Operation** : Manually operated bi-directional system (optional motorized) with dip switch selectable operational modes including controlled access on both sides, one side free (exit or entry) and other side controlled access and access restriction modes.
- Emergency Mode** : System allows free passage in emergency mode and in case of power failure (fail safe default). Fail lock option is available.
- Flow Rate** : Capacity of mechanism (manual system): ~ 60 passages/minute;
nominal: ~18 passages/minute (recommended reference figure).
*Utilisation of different access control units can change the flow rate.
- Optional Accessories and Applications** : LED direction and status indicators, remote control units, interface unit for PC, RS485, RS232 and LAN, counter, audio-messaging system, floor mounting plate, coin slot/intelligent coin system and coin box, card reader pole, seat limiter for stadium solutions, animated indicators, internal battery and charge unit, motor driven unit, heater positive unit, separators, card reader mounting bracket, down light.

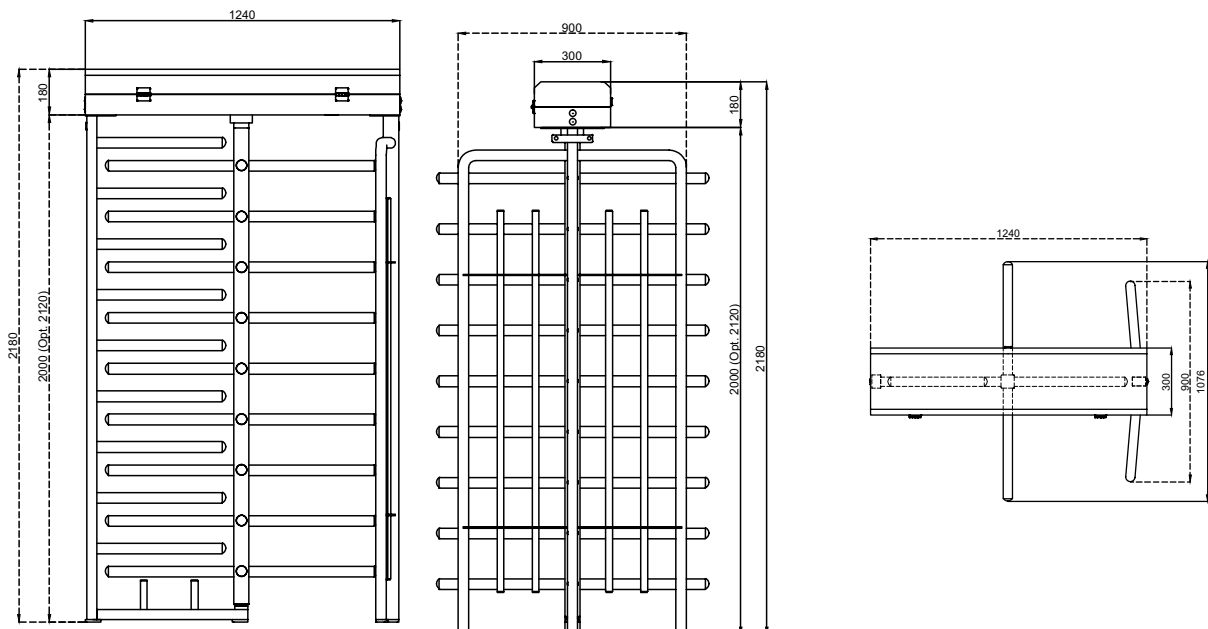

**Design and specifications are subject to change without notice. *All dimensions are in mm.*

ECOLINE 400 D



- Power Requirements** : 110/220-240 V. 60/50Hz. AC (%±10) 24V. DC at standby ~4,5W + ~4,5W. max. ~13,5W + ~13,5W
- Arms Features** : A pair of four-section (90 degrees) rotors. Each section contains ten Ø42mmx2.5mm electrostatic powder coated hot dip galvanized or Ø40mm stainless steel (Opt. Ø38, Ø42 and Ø45mm) arms.
- Body Features** : 304-grade (Opt. 316-grade) brushed finished stainless steel, electrostatic painted surface or mixed combination options. (Opt. hot dip galvanizing under coating for outdoor models).
- Operation Temperature, Humidity, IP Rating, MCBF** : -20°C to + 68°C (Opt. -50°C with heater unit), RH 95% non-condensing / IP 54 outdoor model (Opt. IP 56) / 1M cycles
- Control System** : Manually operated bi-directional system (optional motorized) with dip switch selectable operational modes including controlled access on both sides, one side free (exit or entry) and other side controlled access and access restriction modes.
- Operation** : Manually operated bi-directional system (optional motorized) with dip switch selectable operational modes including controlled access on both sides, one side free exit and restricted access modes.
- Emergency Mode** : The rotor spins freely to allow free passage (fail safe default). Fail lock option is available.
- Flow Rate** : Capacity of mechanism (manual system): ~60 + ~60 passages/minute;
nominal: ~18 + ~18 passages/minute (recommended reference figure).
*Utilisation of different access control units can change the flow rate.
- Optional Accessories and Applications** : LED direction and status indicators, remote control units, interface unit for PC, RS485, RS232 and LAN, counter, audio-messaging system, floor mounting plate, coin slot/intelligent coin system and coin box, card reader pole, seat limiter for stadium solutions, animated indicators, internal battery and charge unit, motor driven unit, heater positive unit, separators, card reader mounting bracket, down light.

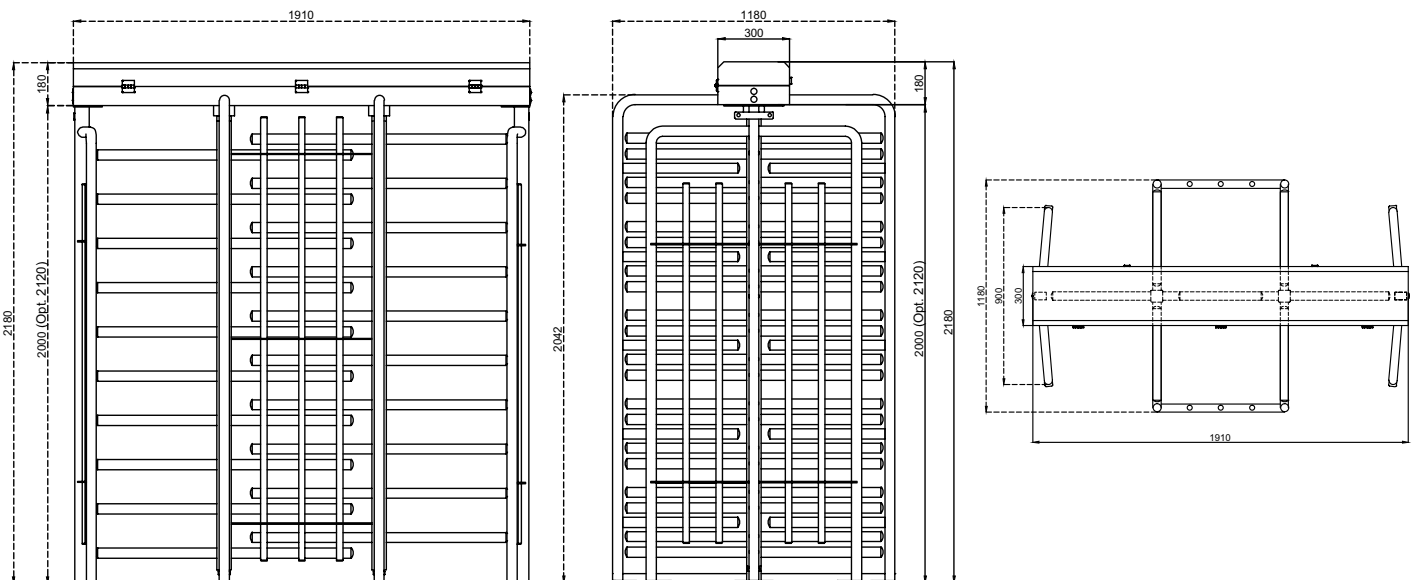

Full Height Turnstiles
Glass & High Security Series



BT 400 GL



- Power Requirements** : 110/220-240 V. 60/50Hz. AC (%±10) 24V. DC at standby ~6W. max. ~16,2W
- Arms Features** : Four-section rotor (90 degrees). Each section comprises of 10mm tempered glass revolving wings.
- Body Features** : The main supporting structure is made of aluminium with tempered glass side walls. Water resistant top cover with matching aluminum frame around.
- Operation Temperature, Humidity, IP Rating, MCBF** : -20°C to +68°C (Opt. -50°C with heater unit), RH 95% non-condensing / IP 54 outdoor model (Opt. IP 56) / 1M cycles.
- Control System** : All inputs are opto-coupler protected. Controlled by dry contact or grounding input. Compatible with all access control systems that provide dry contact or grounding outputs. Optional RS232/RS485/TCP IP control module is available.
- Operation** : Motorized bi-directional system (optional Manual) with dip switch selectable operational modes including controlled access on both sides, one side free (exit or entry) and other side controlled access and access restriction modes.
- Emergency Mode** : System allows free passage in emergency mode and in case of power failure (fail safe default). Fail lock option is available.
- Flow Rate** : Capacity of mechanism (manual system): ~48
nominal: ~15 passages/minute (recommended reference figure).
*Utilisation of different access control units can change the flow rate.
- Standard Features** : LED direction/ status indicators, LED illuminated ceiling light.
- Optional Accessories and Applications** : Remote control units, interface unit for PC, RS485, RS232 and LAN, counter, audio-messaging system, floor mounting plate, coin slot/ intelligent coin system and coin box, card reader pole, seat limiter for stadium solutions, animated indicators, internal battery and charge unit, heater positive unit, separators, card reader mounted bracket, down light.

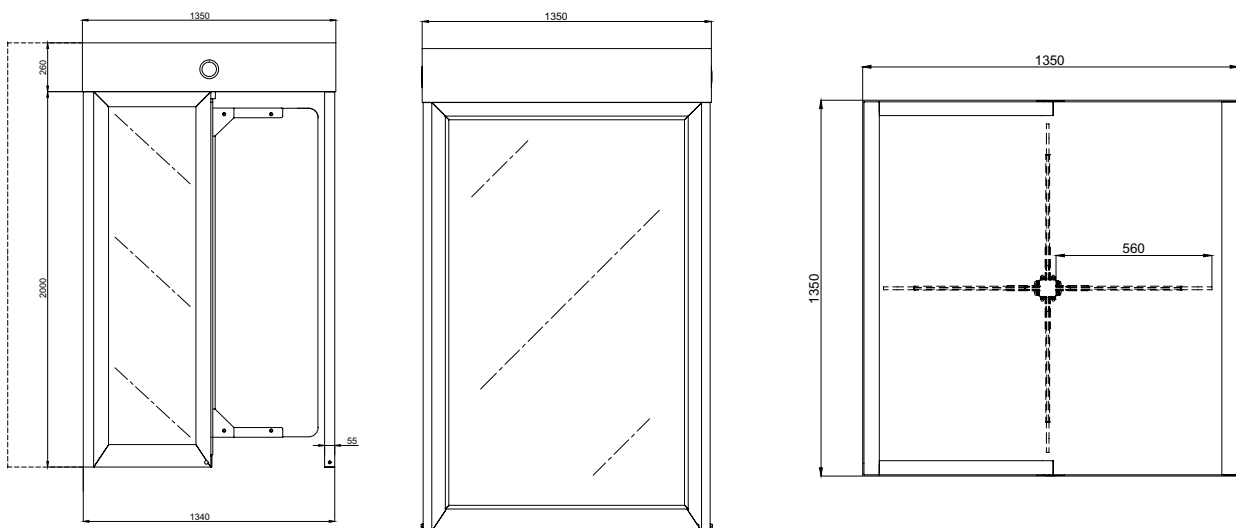



BT 302 GL



- Power Requirements** : 110/220-240 V. 60/50Hz. AC (%±10) 24V. DC at standby ~6,8W. max. ~17W.
- Wing Features** : Three-section rotor (120 degrees). Each section comprises 6+6mm laminated (Opt. tempered) glass revolving wings.
- Body Features** : The main frame structure is made of 304 grade stainless steel with 6+6 mm laminated (Opt. tempered) glass side walls. Water resistant top cover with matching stainless steel frame around. Service and maintenance from the ceiling of cabin.
- Operating Temperature, Humidity, IP Rating, MCBF** : -20°C to +68°C (Opt. -50°C with heater unit), RH 95% non-condensing / IP 54 outdoor model (Opt. IP 56) / 1M cycles
- Control System** : All inputs are opto-coupler protected. Controlled by dry contact or grounding input. Compatible with all access control systems that provide dry contact or grounding outputs. Optional RS232/RS485/TCP IP control module is available.
- Operation** : Manually operated bi-directional system (optional motorized) with dip switch selectable operational modes including controlled access on both sides, one side free (exit or entry) and other side controlled access and access restriction modes.
- Emergency Mode** : The rotor spins freely to allow free passage (fail-safe default). Fail lock option is available.
- Flow Rate** : Capacity of mechanism (manual system): ~60 passages/minute; nominal: ~18 passages/minute (recommended reference figure).
*Utilisation of different access control units can change the flow rate.
- Standard Features** : DOT matrix direction / status indicators, LED illumination on the ceiling.
- Optional Accessories and Applications** : Remote control units, interface unit for PC, RS485, RS232 and LAN, counter, audio-messaging system, floor mounting plate, card reader pole, animated indicators, internal battery and charge unit, heater positive unit, separators, card reader mounting bracket, photocell sensors for preventing unauthorized passage.

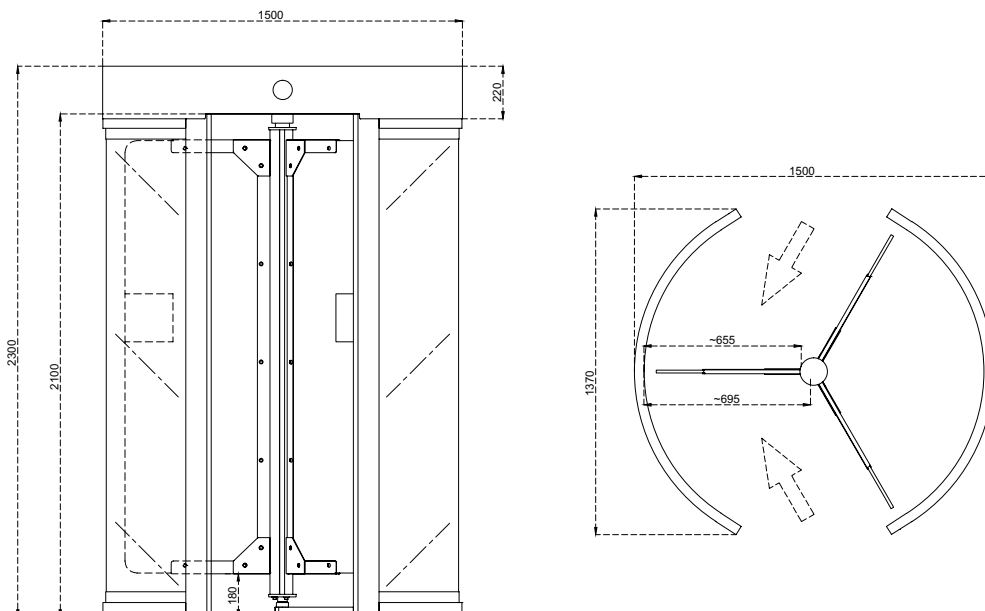

**Design and specifications are subject to change without notice. *All dimensions are in mm.*

BT 402 GL



- Power Requirements** : 110/220-240 V. 60/50Hz. AC (%±10) 24V. DC at standby ~6,8W. max. ~17W
- Wing Features** : Four-section rotor (90 degrees). Each section comprises 6+6mm laminated (Opt. tempered) glass revolving wings.
- Body Features** : The main frame structure is made of 304 grade stainless steel with 6+6 mm laminated (Opt. tempered) glass side walls. Water resistant top cover with matching stainless steel frame around. Service and maintenance from the ceiling of cabin.
- Operating Temperature, Humidity, IP Rating, MCBF** : -20°C to +68°C (Opt. -50°C with heater unit), RH 95% non-condensing / IP 54 outdoor model (Opt. IP 56) / 1M cycles
- Control System** : All inputs are opto-coupler protected. Controlled by dry contact or grounding input. Compatible with all access control systems that provide dry contact or grounding outputs. Optional RS232/RS485/TCP IP control module is available.
- Operation** : Manually operated bi-directional system (optional motorized) with dip switch selectable operational modes including controlled access on both sides, one side free (exit or entry) and other side controlled access and access restriction modes.
- Emergency Mode** : The rotor spins freely to allow free passage (fail-safe default). Fail lock option is available.
- Flow Rate** : Capacity of mechanism (manual system): ~60 passages/minute; nominal: ~18 passages/minute (recommended reference figure).
*Utilisation of different access control units can change the flow rate.
- Standard Features** : DOT matrix direction / status indicators, LED illumination on the ceiling.
- Optional Accessories and Applications** : Remote control units, interface unit for PC, RS485, RS232 and LAN, counter, audio-messaging system, floor mounting plate, card reader pole, animated indicators, internal battery and charge unit, heater positive unit, separators, card reader mounting bracket, photocell sensors for preventing unauthorized passage.

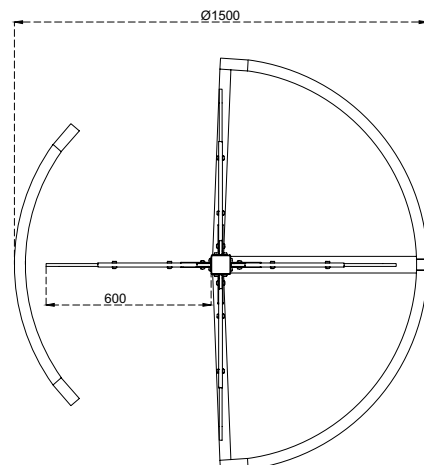
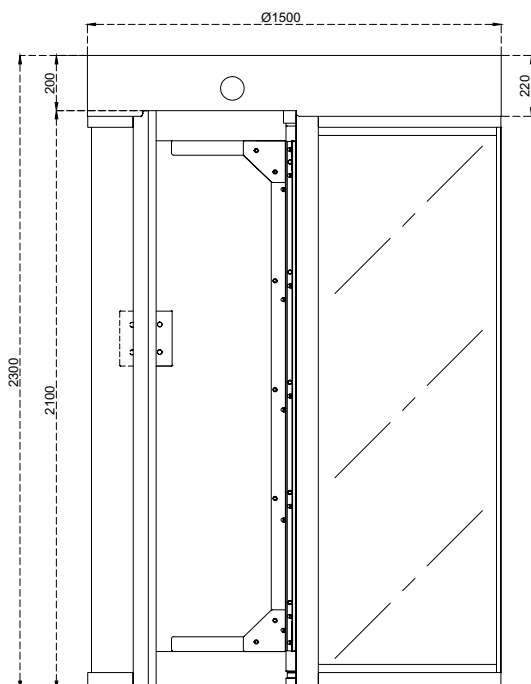

**Design and specifications are subject to change without notice. *All dimensions are in mm.*



CGC 100



- Power Requirements** : 110/220-240 V. 60/50Hz. AC (%±10) 24V. DC at standby ~14 W. max. ~130 W
- Body Features & Circular Sliding Doors** : Cylindrical shaped, 1,5 mm thick, 304 grade stainless steel
Control unit is located above the ceiling panel on top cabinet.
Interior-Motor-Driven rotating cylindrical cabinet provides controlled by directional access.
- Operation Temperature, Humidity, IP Rating, MCBF** : -20°C to +68°C / RH 95% non-condensing / IP 44 indoor model / 1 M cycles
- Control System** : All inputs are opto-coupler protected. Controlled by dry contact or grounding input. Compatible with all access control systems that provide dry contact or grounding outputs. Optional RS232/RS485/TCP IP control module is available.
- Operation** : Electronically controlled DC motor driven bi-directional system for access control in high security installations.
- Emergency Mode** : System allows free passage (manual push to rotate) in emergency mode and in case of power failure.
- Flow Rate** : Capacity of mechanism: ~2 passages/minute;
nominal: ~2 passages/minute (recommended reference figure).
*Utilisation of different access control units can change the flow rate.
- Standard Features** : Direction and status Indicators, IR height sensor
- Optional Accessories and Applications** : Weight sensor.

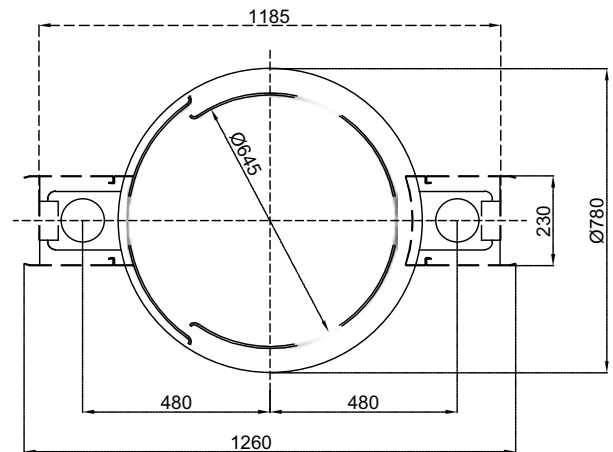
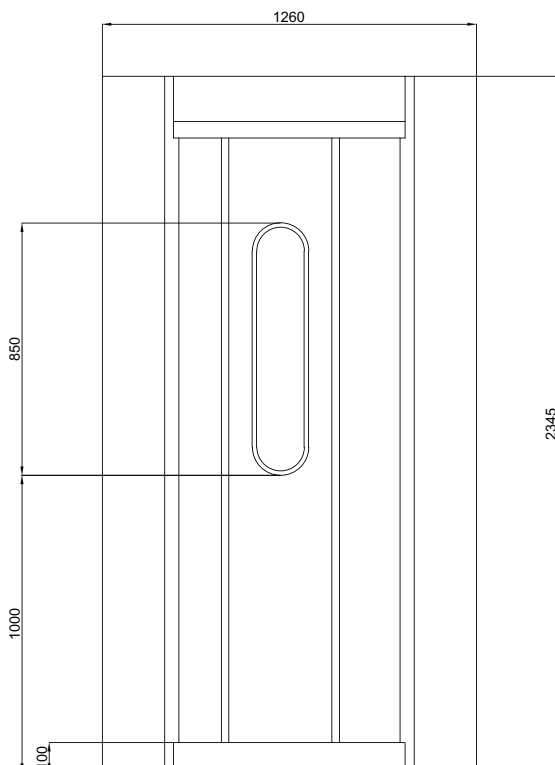

**Design and specifications are subject to change without notice. *All dimensions are in mm.*

CGG 100



- Power Requirements** : 110/220-240 V. 60/50Hz. AC (%±10) 24V. DC at standby ~14 W. max. ~130 W
- Body Features & Circular Sliding Doors** : Cylindrical shaped, 1,5 mm thick, 304-grade stainless steel.
Exterior-fixed access doors located between the supporting structure and the wall.
Control unit is located above the ceiling panel on top cabinet.
Interior-motor-driven rotating cylindrical cabinet provides control by directional access.
- Operation Temperature, Humidity, IP Rating, MCBF** : -20°C to +68°C / RH 95% non-condensing / IP 44 indoor model / 1 M cycles
- Control System** : All inputs are opto-coupler protected. Controlled by dry contact or grounding input. Compatible with all access control systems that provide dry contact or grounding outputs. Optional RS232/RS485/TCP IP control module is available.
- Operation** : Electronically controlled DC motor driven bi-directional system for access control in high security installations.
- Emergency Mode** : System allows free passage (manual push to rotate) in emergency mode and in case of power failure.
- Flow Rate** : Capacity of mechanism: ~2 passages/minute;
Nominal: ~2 passages/minute (recommended reference figure).
*Utilisation of different access control units can change the flow rate.
- Standard Features** : Direction and status indicators, IR height sensor
- Optional Accessories and Applications** : Weight sensor, bullet-proof glass.

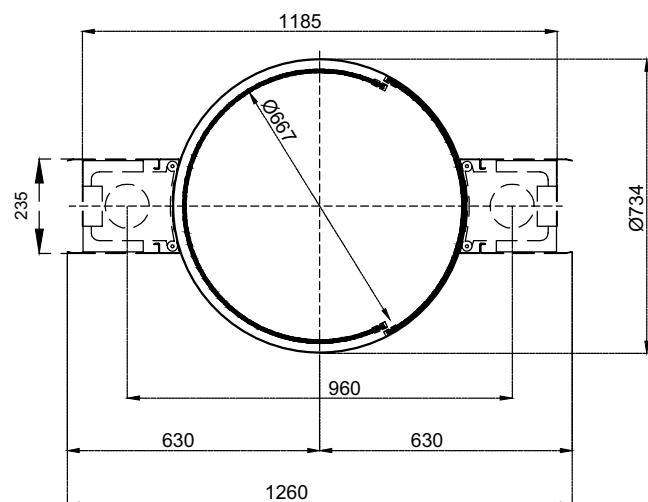
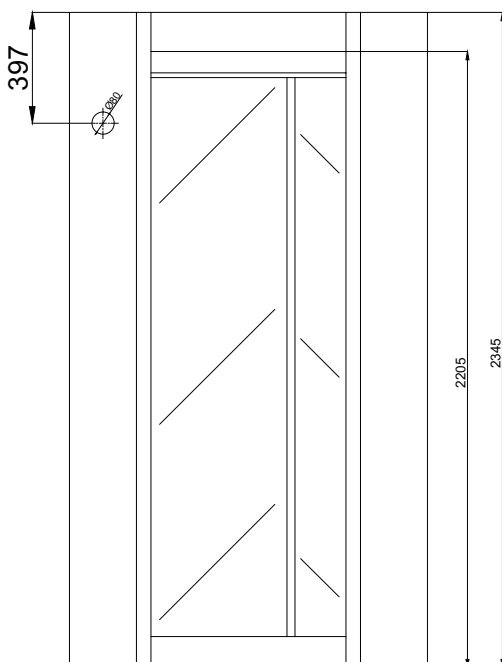



Madenwañ
sektöü ilek
yeni zelli

3

PEDESTRIAN GATE

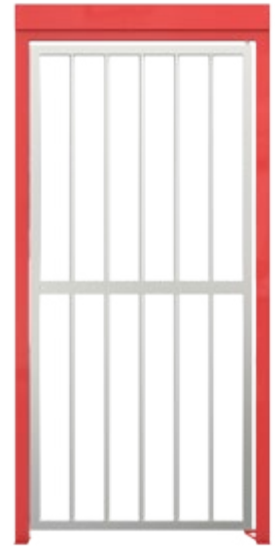

- Power Requirements** : 24v DC. at standby 360 mA, at operation 900 mA
- Body Features** : All parts of the construction are powder coated galvanised mild steel or 304-grade stainless steel, protected against water for outdoor use. Passage width: 900 mm. Complying to UK H&S regulations of max. 98 mm gap between upright profiles.
- System Features** : Single-directional operation. Can be integrated with full height turnstiles, fence systems or indoor/outdoor partition walls
- Operation Temperature, Humidity, IP Rating, MCBF** : -20°C to +68°C (Opt. -50°C with heater unit), RH 95% non-condensing / IP 54 outdoor model (Opt. IP 56) / 1M cycles
- Control System** : Controlled by dry contact or grounding input. Compatible with all access control systems that provide dry contact or grounding outputs. Optional RS232/RS485/TCP IP control module is available.
- Optional Accessories and Applications** : Electromagnetic lock with alert buzzer, green - red status indicators, automatic door closer, dead-bolt-lock, installation panels for various applications. Capability of using as emergency exit gate after adaptation.

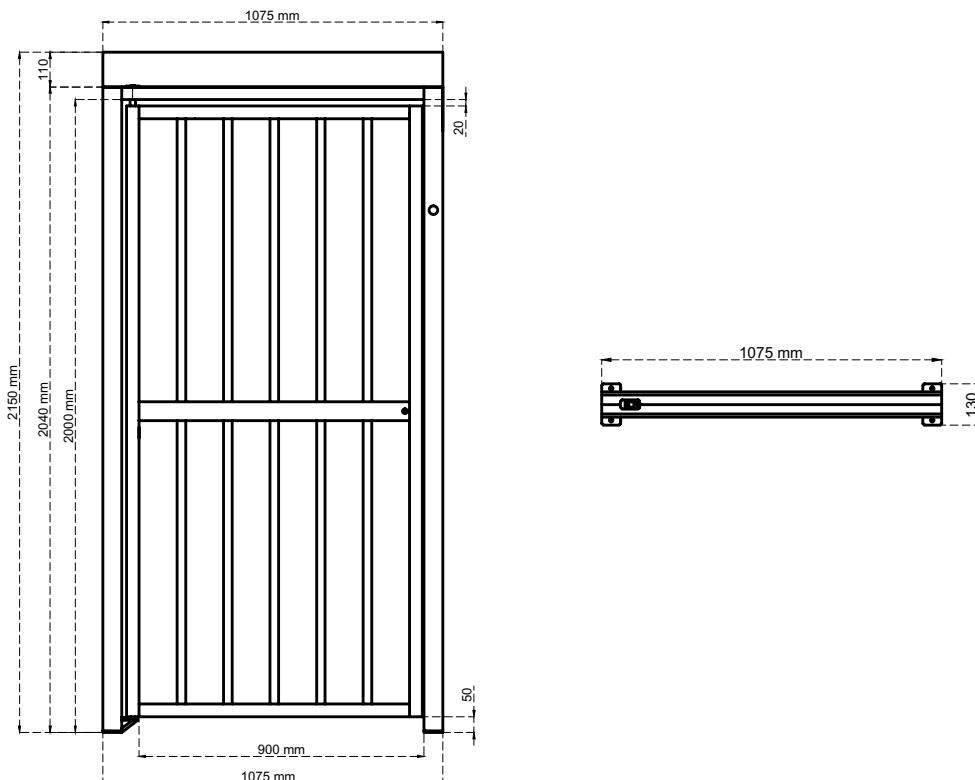

CONTAINER for Turnstile

Movable Turnstiles



Construction Sites

Activities

Concerts

Festivals

Events

Stadiums



**Design and specifications are subject to change without notice. *All dimensions are in mm.*

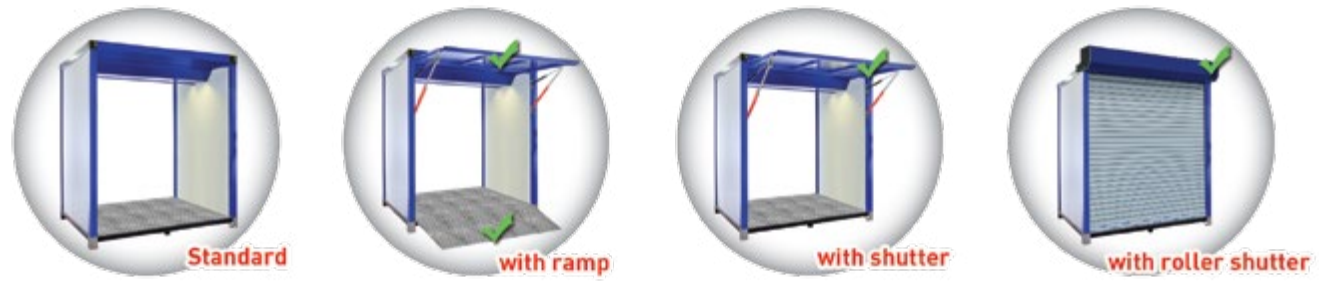
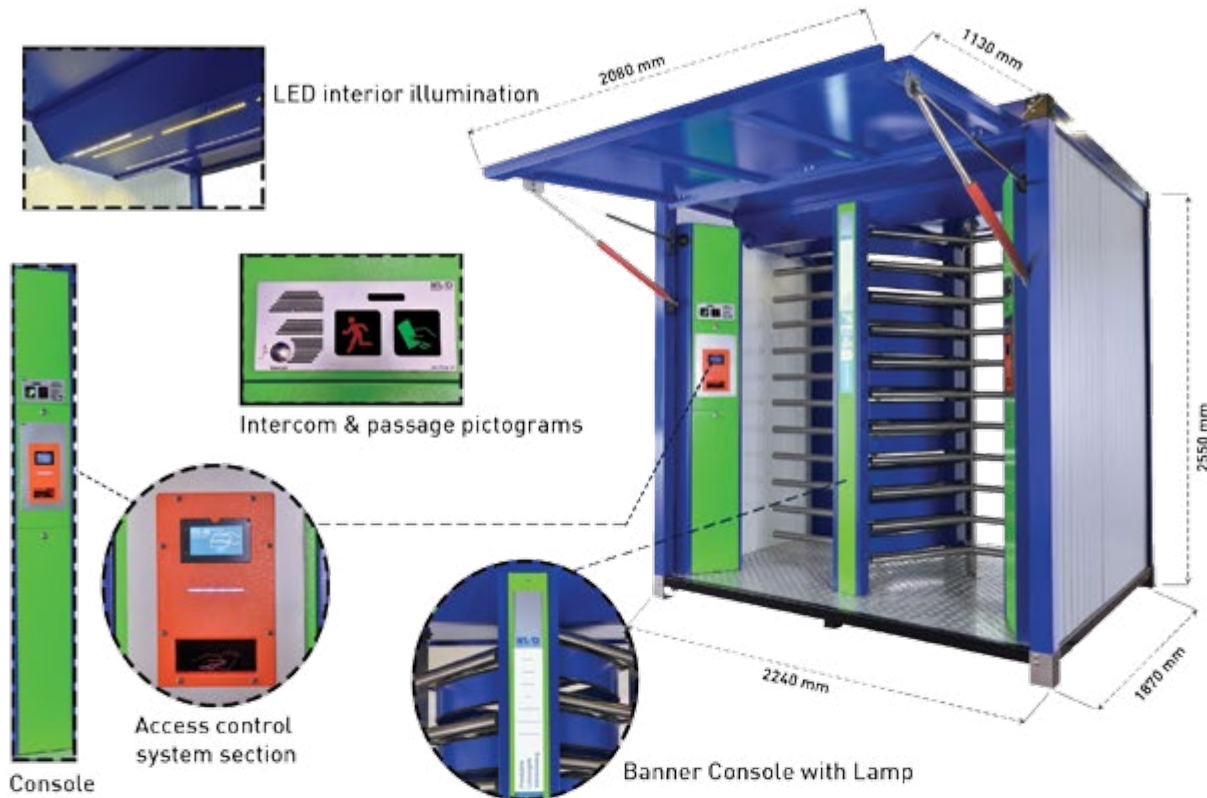

- Dimensions** : 2240 x 1870 x 2550 mm (2250 x 2170 x 2750 mm roller shutter)(Optional dimensions are available).
- Exterior Casing Material** : 45 - 50 mm composite panel (Optional materials are available).
- Standard Features** : 3 mm bottom chassis + roof with 4 rain gutters + all construction electrostatic coated over hot dip galvanization.
- Mobility** : Can be lifted and moved from the top by crane.
Can be lifted and moved from the bottom by forklift or pallet truck
- Accessories** : LED daylight interior illumination, room: data + phone line + (110/220V) plug and 2 shelves, top shutter opening upwards (wing), ramp for wheelchair access, illuminated advertisement billboard, access console.
The following combination options are available.

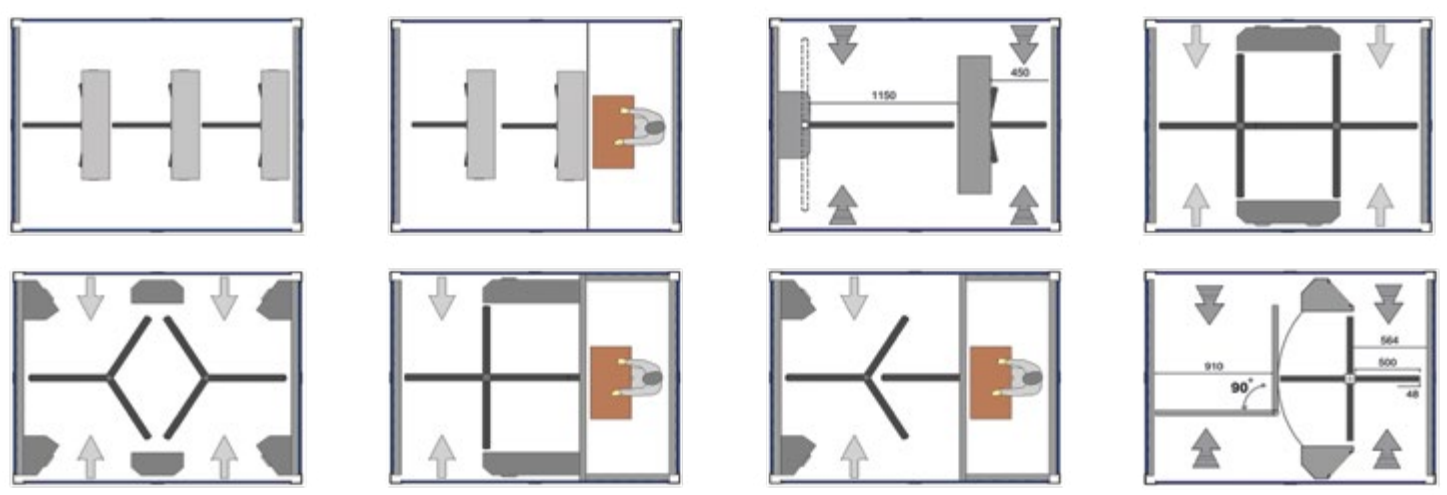

*Design and specifications are subject to change without notice. *All dimensions are in mm.

CUSTOMISATIONS



ACCESSORIES



Automatic Drop (retractable) Arm



Manual Controls



Counter



Coin Mechanism



Illumination



Card Reader Mounting Poles



Card Reader Mounting Brackets







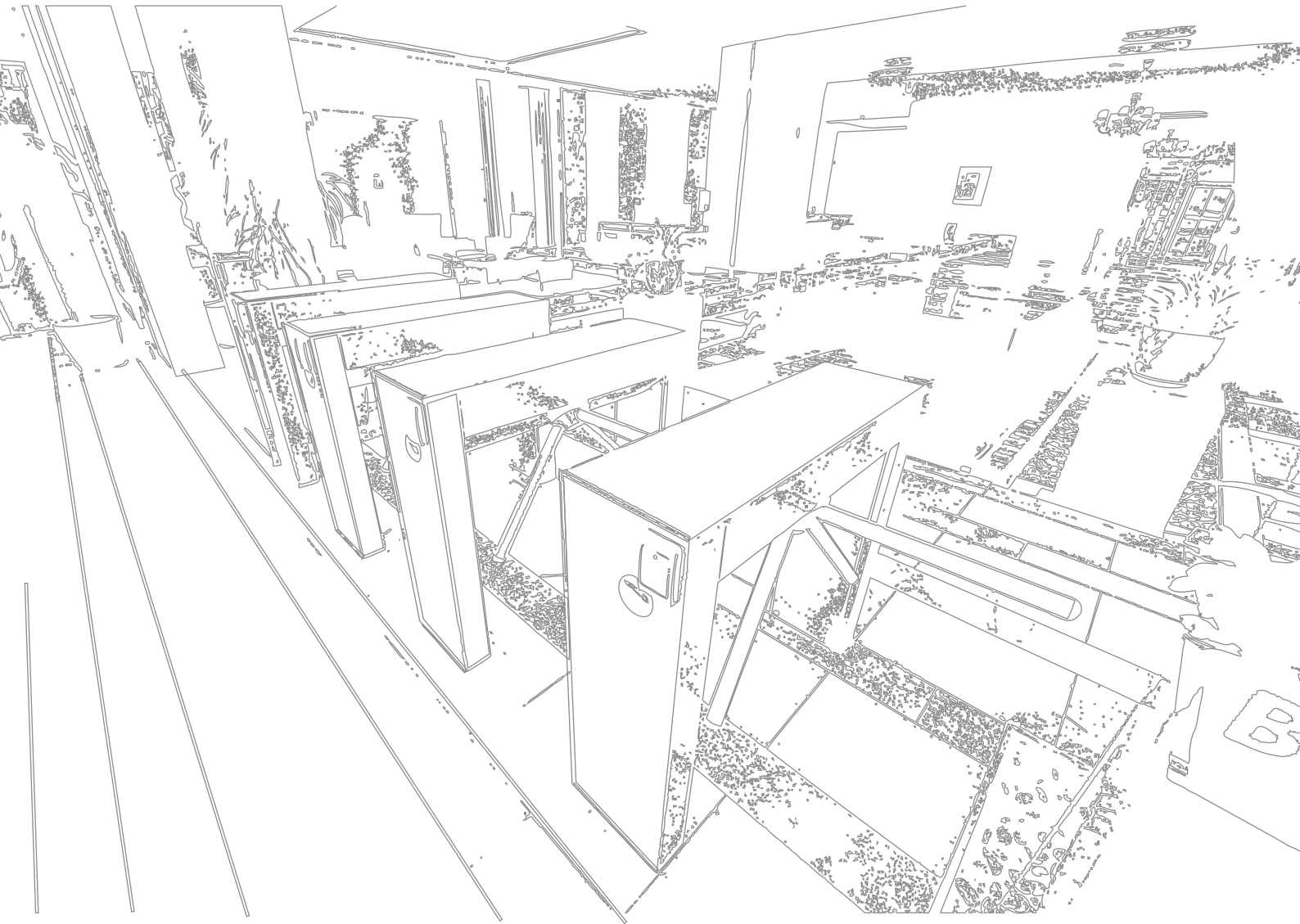

Çuhane Cd. N: 130
Köseköy / Kartepe / Kocaeli / TÜRKİYE

T: +90 262 373 48 48
F: +90 262 373 48 48
E: ozak@ozak-t.com



KOSGEB
www.kosgeb.gov.tr

05.04.2017
DD-72-282 R(5)